

T-8421A T-8422A

零件手册
PARTS BOOK

双针直接驱动式平缝机 [T-8421A]

TWIN NEEDLE LOCK STITCHER[T-8421A]

双针直接驱动式自动切线平缝机[T-8422A]

TWIN NEEDLE DIRECT DRIVE LOCK STITCHER WITH THREAD TRIMMER
[T-8422A]

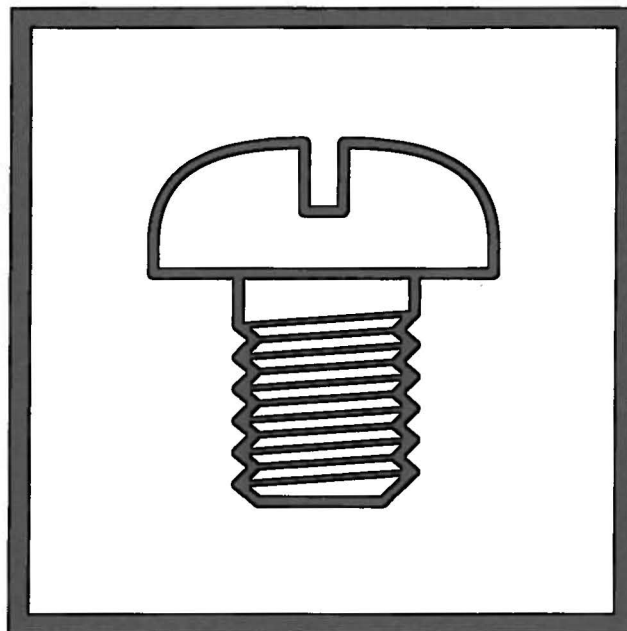

brother®

最新的零部件情报请参考(Parts Navigation)。

<http://partsbook.brother.co.jp/partsnavi/chn/index.html>

The latest parts information, refer to the Parts Navigation. <http://partsbook.brother.co.jp/partsnavi/eng/index.html>

From the library of: Superior Sewing Machine & Supply LLC

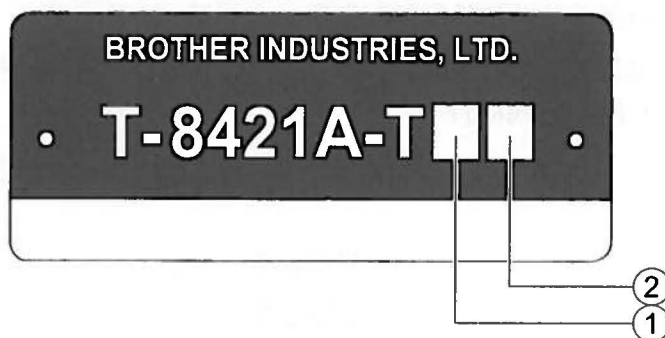

- ① — 0: 微油型规格 / Minimum lubrication type
- 3: 针杆无油型规格 / Semi dry type

- ② — 3: 中厚布料 / Medium-weight materials
- 5: 厚布料 / Heavy-weight materials
- F: 女性内衣 / Foundation garments

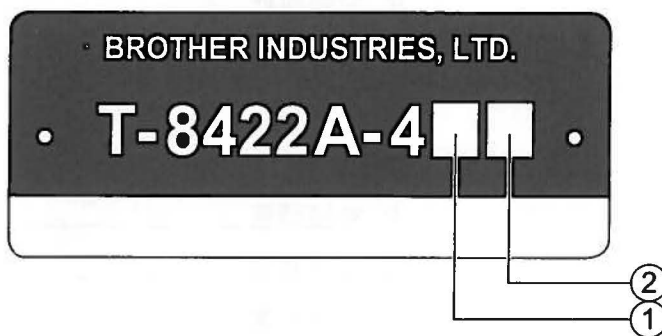

- ① — 0: 微油型规格 / Minimum lubrication type
- 3: 针杆无油型规格 / Semi dry type

- ② — 3: 中厚布料 / Medium-weight materials
- 5: 厚布料 / Heavy-weight materials

零件手册的使用说明

1. 本手册是根据截止至2004年05月的资料为基准而编制的。
2. 零部件设计若有变动，恕不另行通知。
3. 以组件为单位供应的部件用 框出。
4. 如果在零部件序号栏中有 * 的记号，请参考不同规格零部件一览表及工模具一览表。
(第54页~66页)

目 录

A. 机体部分	1
B. 上轴装置	3
C. 针杆摆动装置	5
D. 压脚装置	7
E. 送布装置	9
F. 倒缝装置	11
G. 倒缝开关装置	11
H. 送布轴装置	13
J1. 旋梭装置 (T-8421A)	15
J2. 旋梭装置 (T-8422A)	19
J3. 旋梭装置	23
K. 定规部件	23
L. 下轴装置	25
M. 松线装置 (T-8422A)	25
N. 供油润滑装置	27
P. 穿线装置	31
Q. 卷线装置	33
R. 切线装置	35
S. 扫线装置 (T-8422A)	37
T1. 控制箱·马达装置	39
T2. 控制箱装置	41
U. 电气部品(开关)装置	45
V. 电磁抬压脚组件装置(选购件)	47
Z1. 附件	49
Z2. 附件	51
Wa. 警告标签	53
Sp. 不同规格零部件一览表	54
Ga1. 工模具一览表 (T-8421A)	56
Ga2. 工模具一览表 (T-8422A)	63
索引	67

Notes for using this parts book

1. This book was prepared based on information available in May 2004.
2. Parts are subject to changes in design without prior notice.
3. Parts supplied as complete assemblies are circled by a dotted line .
4. If the symbol * is found in the " Parts No." column, refer to the different parts lists, gauge parts list on page 54 -66.

CONTENTS

A. Machine body	1
B. Upper shaft mechanism	3
C. Needle bar rocking mechanism	5
D. Presser foot mechanism	7
E. Feed mechanism	9
F. Quick reverse mechanism	11
G. Quick reverse switch mechanism	11
H. Feed shaft mechanism	13
J1. Rotary hook mechanism (T-8421A)	15
J2. Rotary hook mechanism (T-8422A)	19
J3. Rotary hook mechanism	23
K. Gauge parts	23
L. Lower shaft mechanism	25
M. Tension release mechanism (T-8422A).....	25
N. Lubrication	27
P. Threading mechanism	31
Q. Bobbin winder mechanism	33
R. Thread trimmer mechanism	35
S. Thread wiper mechanism (T-8422A)	37
T1. Control box & motor mechanism	39
T2. Control box mechanism	41
U. Power supply equipment mechanism	45
V. Presser foot lifting solenoid set mechanism (Option parts)	47
Z1. Accessories	49
Z2. Accessories	51
Wa. Warning labels	53
Sp. Different parts list	54
Ga1. Gauge parts list (T-8421A)	56
Ga2. Gauge parts list (T-8422A)	63
Index	67

A. 机体部分 / Machine body

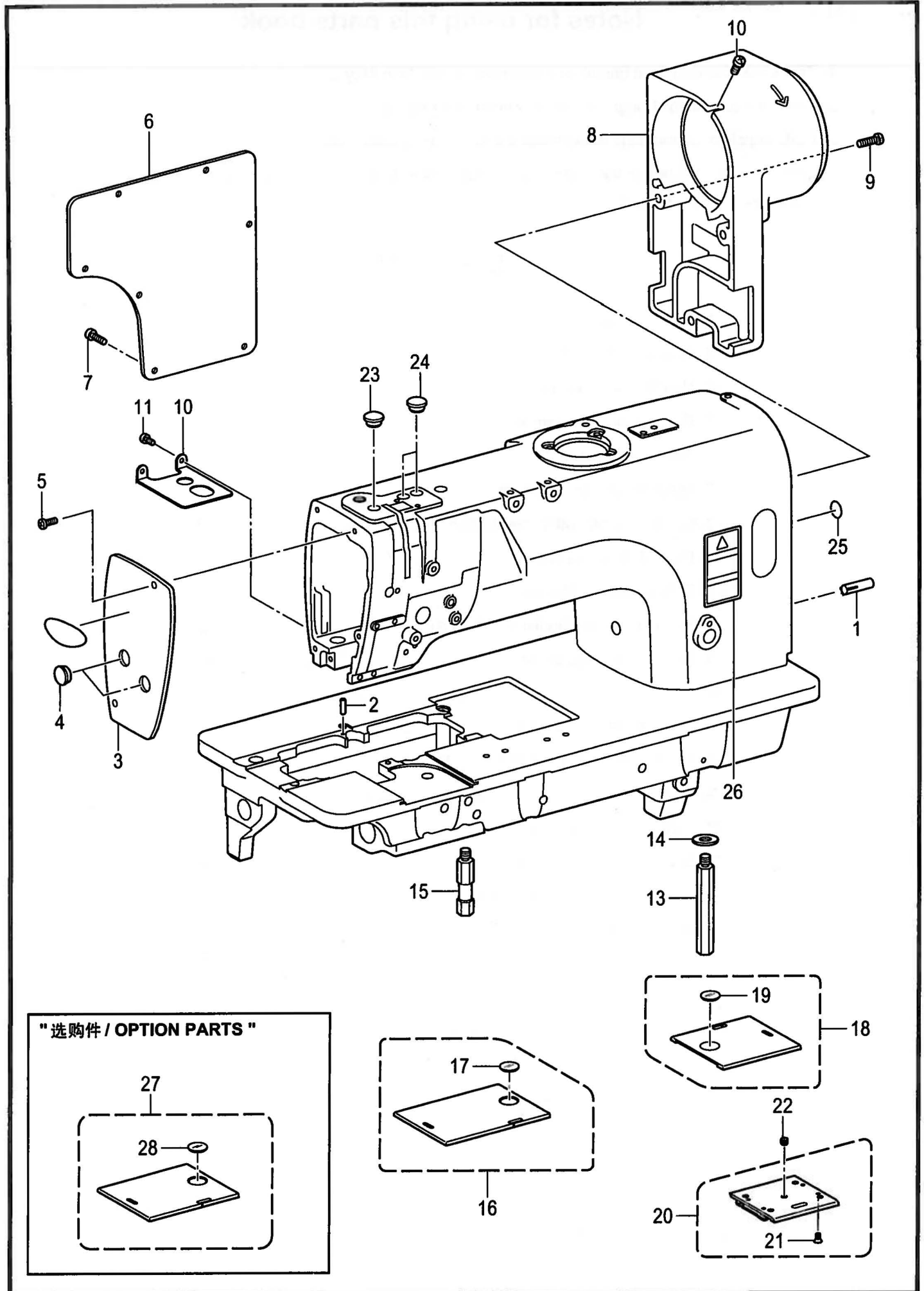

T-8421A/8422A-050

A. 机体部分 / Machine body

参照号	零部件序号	数量	零部件名称	NAME OF PARTS	RM
1	140063001	2	带槽销	DOWEL PIN	
2	SA3924001	1	定位销	POSITIONING PIN	
3	SA2440001	1	主板	FACE PLATE	
4	SA2929001	2	橡皮塞 12.5	RUBBER CAP, 12.5	
5	062500816	2	螺钉 M5X8	SCREW, PAN M5X8	
6	SA2441001	1	侧板	REAR COVER	
7	062501216	7	螺钉 M5X12	SCREW, PAN M5X12	
8	SA2442001	1	马达罩	MOTOR COVER	
9	062501416	3	螺钉 M5X14	SCREW, PAN M5X14	
10	062501016	1	螺钉 M5X10	SCREW, PAN M5X10	
11	SA2443001	1	防尘板	DUST PROTECTOR	
12	062500616	2	螺钉 M5X6	SCREW, PAN M5X6	
13	SA2444101	1	脚柱 L	BED LEG,L	
14	025080236	1	平垫圈 M8	WASHER, PLAIN M 8	
15	SA2445001	1	脚柱 S	BED LEG,S	
16	SA2447001	1	推板LA组件	SLIDE PLATE, LA ASSY	
17	SA2479001	1	推板窗	BOBBIN WINDOW	
18	SA2449001	1	推板R组件	SLIDE PLATE ASSY, R	
19	SA2479001	1	推板窗	BOBBIN WINDOW	
20	S36663051	1	前推板组件	SLIDE PLATE F ASSY	
21	S34438051	4	螺钉 SM3.18-40X4	SCREW, FLAT SM3.18-40X4	
22	116010001	1	螺钉 SM5.16-40X4	SET SCREW, SM5.16-40X4	
23	SA2929001	1	橡皮塞 12.5	RUBBER CAP, 12.5	
24	SA2929001	2	橡皮塞 12.5	RUBBER CAP, 12.5	
25	S37060001	1	接地标记	LABEL, GROUNDING	
26	SA2040001	1	<用于日本> 操作注意标签(日/英)	< For Japan only > LABEL, CAUTION JPN/ENG	
26	SA2041001	1	<用于日本以外> 操作注意标签(中/英)	< Except for Japan > LABEL, CAUTION CHN/ENG	
27	SA2761001	1	"选购件" 推板LB组件	"OPTION PARTS" SLIDE PLATE, LB ASSY	
28	SA2479001	1	推板窗	BOBBIN WINDOW	

B. 上轴装置 / Upper shaft mechanism

< 微油型规格, 用于 -□0□ / For "-□0□" Minimum lubrication type >

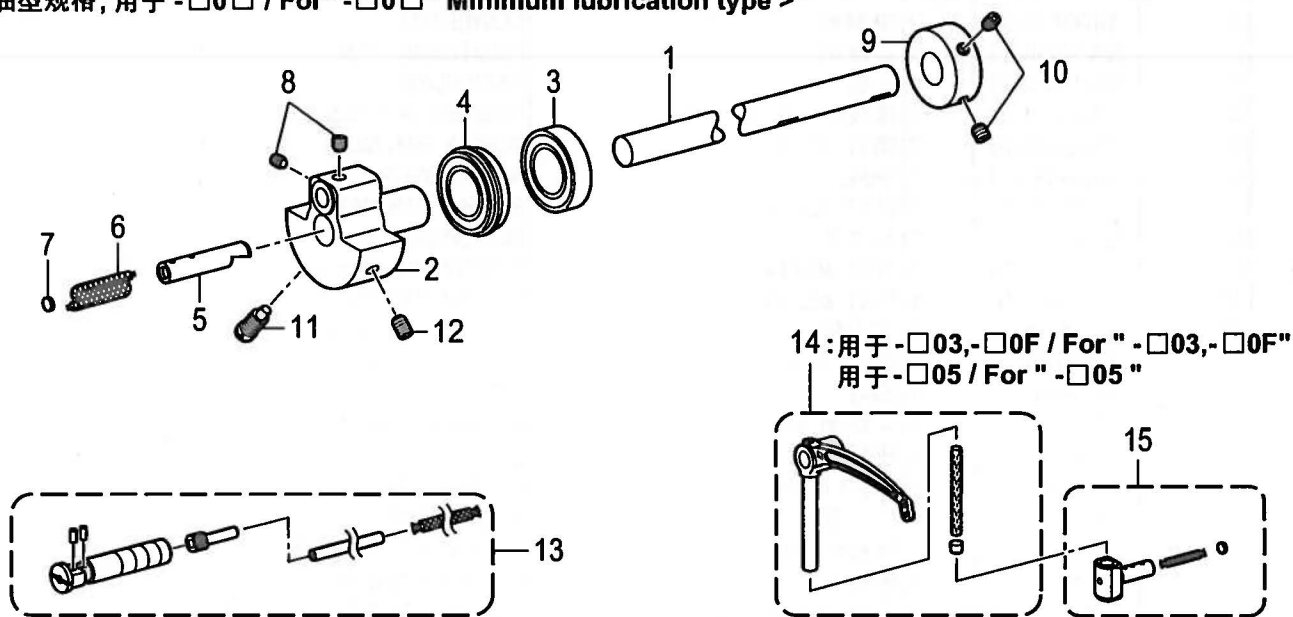

< 针杆无油型规格, 用于 -□3□ / For "-□3□" Semi dry type >

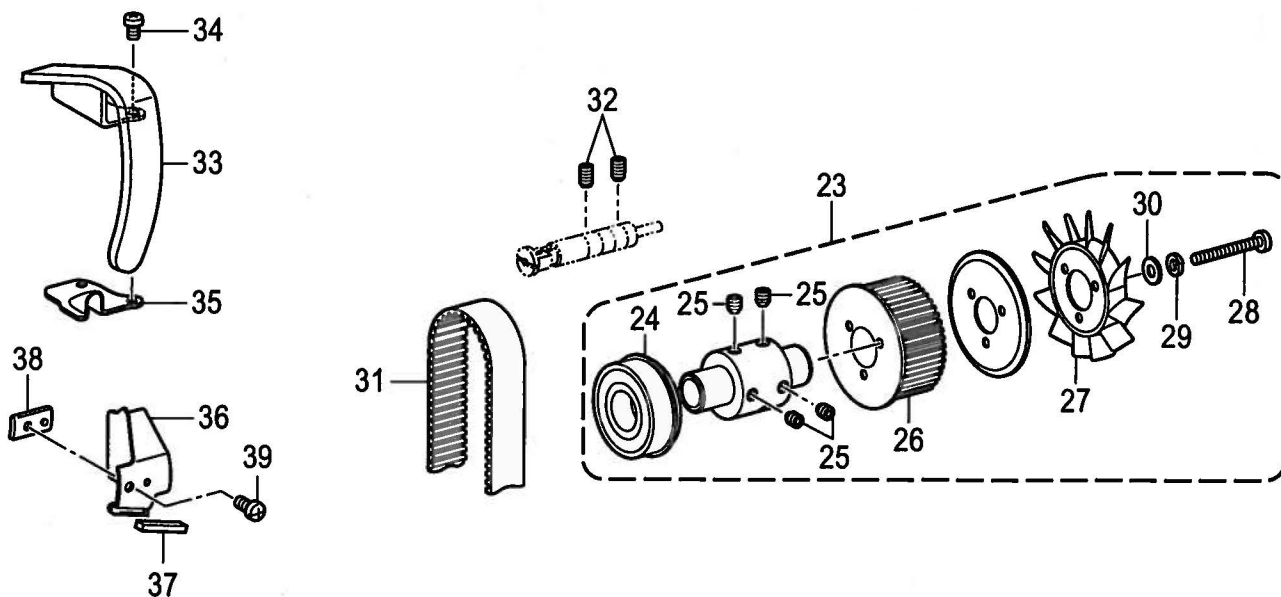
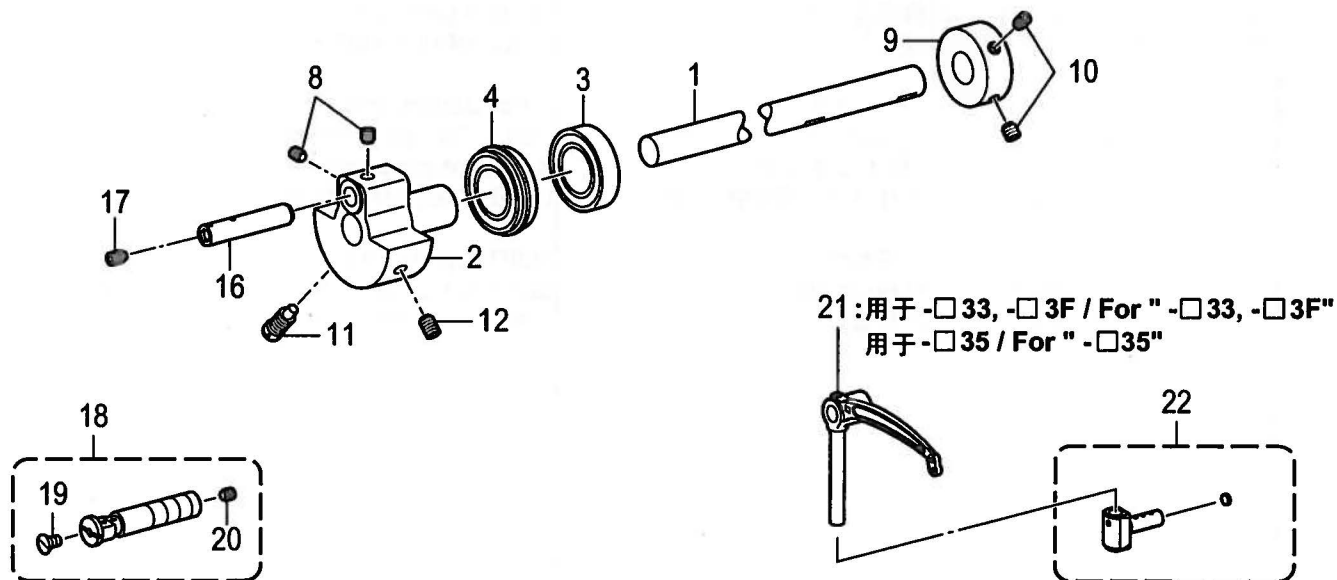

B. 上轴装置 / Upper shaft mechanism

参照号	零部件序号	数量	零部件名称	NAME OF PARTS	RM
			<用于-□0□>	<For"-□0□">	
1	SA2452101	1	上轴 DD	UPPER SHAFT, DD	
2	SA4089001	1	挑线杆曲柄	THREAD TAKE-UP CRANK	
3	S25234001	1	球轴承 6004ZZ	BALL BEARING, 6004ZZ	
4	S38707001	1	球轴承 6004ZZNR	BALL BEARING, 6004ZZNR	
5	S38398001	1	针杆曲柄轴	CRANKSHAFT, N-BAR	
6	SA4335001	1	油线 6X6 L=90	WICK,6X6 (L=90)	
7	113014000	1	油线盖	PUSHER	
8	S25260001	2	固定螺钉 M6X5	SET SCREW, SOCKET (FT) M6X5	
9	SA1120001	1	卷线驱动轮	BOBBIN WINDER DRIVING WHEEL	
10	S23651001	2	固定螺钉 M6X6	SET SCREW, SOCKET (FT) M6X6	
11	S25235001	1	螺钉 M8	SCREW, M8	
12	S25236001	1	螺钉 M6X10	SET SCREW, SOCKET (FT) M6X10	
13	SA2861001	1	挑线杆支撑轴总组件	THREAD TAKE-UP S-SHAFT UNIT	
			<用于-□03, -□0F>	<For"-□03,-□0F">	
14	SA2935101	1	挑线杆S3-L组件	THREAD TAKE-UP LEVER ASSY,S3-L	
			<用于-□05>	< For"-□05">	
14	SA2936101	1	挑线杆S5-L组件	THREAD TAKE-UP LEVER ASSY,S5-L	
			<用于-□0□>	<For"-□0□">	
15	S13160001	1	挑线杆接头滑块组件 2	T-TAKE-UP SLIDE BLOCK ASSY, 2	
<hr/>					
			<用于-□3□>	<For"-□3□">	
1	SA2452101	1	上轴 DD	UPPER SHAFT, DD	
2	SA4089001	1	挑线杆曲柄	THREAD TAKE-UP CRANK	
3	S25234001	1	球轴承 6004ZZ	BALL BEARING, 6004ZZ	
4	S38707001	1	球轴承 6004ZZNR	BALL BEARING, 6004ZZNR	
16	SA4112001	1	挑线杆曲柄轴P	THREAD TAKE-UP CRANK SHAFT, P	
17	014500836	1	螺钉 M5X8	SET SCREW, SOCKET (CP) M5X8	
8	S25260001	2	固定螺钉 M6X5	SET SCREW, SOCKET (FT) M6X5	
9	SA1120001	1	卷线驱动轮	BOBBIN WINDER DRIVING WHEEL	
10	S23651001	2	固定螺钉 M6X6	SET SCREW, SOCKET (FT) M6X6	
11	S25235001	1	螺钉 M8	SCREW, M8	
12	S25236001	1	螺钉 M6X10	SET SCREW, SOCKET (FT) M6X10	
18	SA2464001	1	挑线杆支架轴组件	THREAD TAKE-UP S-SHAFT ASSY	
19	SA2958001	1	螺钉 M5X6	SCREW, FLAT M5X6	
20	012500536	1	螺钉 M5X5	SET SCREW, SOCKET (FT) M5X5	
			<用于-□33, -□3F>	<For"-□33,-□3F">	
21	SA4115001	1	挑线杆 S3P	THREAD TAKE-UP LEVER, S3 P	
			<用于-□35>	< For"-□35">	
21	SA4166001	1	挑线杆 S5P	THREAD TAKE-UP LEVER ,S5 P	
			<用于-□3□>	<For"-□3□">	
22	SA4129001	1	挑线杆接头滑块组件	THREAD TAKE-UP SLIDE B-ASSY	
<hr/>					
23	SA2460001	1	接头复合件	PRESSER ADJUSTING UNIT	
24	S38710001	1	球轴承 6204ZZNR	BALL BEARING, 6204ZZNR	
25	S23651001	4	固定螺钉 M6X6	SET SCREW, SOCKET (FT) M6X6	
26	SA2461001	1	同步轮 U DD	TIMING PULLEY, U DD	
27	S38713100	1	叶轮	FAN	
28	062403512	3	螺钉 M4X35	SCREW, PAN M4X35	
29	028040242	3	弹簧垫圈 2-4	WASHER, SPRING 2-4	
30	025040232	3	平垫圈 M4	WASHER, PLAIN M 4	
31	SA2463001	1	同步皮带	TIMING BELT	
32	012061036	2	螺钉 M6X10	SET SCREW, SOCKET (FT) M6X10	
33	SA2469001	1	挑线杆防护罩	THREAD TAKE-UP LEVER COVER	
34	062500816	2	螺钉 M5X8	SCREW, PAN M5X8	
35	SA3057001	1	防尘盖	DUST COVER	
36	SA3058101	1	遮掩板	SHELTER PLATE	
37	SA3065001	1	油毡	FELT	
38	SA3059001	1	遮掩板支座	HOLDER, SHELTER PLATE	
39	062500816	1	螺钉 M5X8	SCREW, PAN M5X8	

C. 针杆摆动装置 / Needle bar rocking mechanism

< 微油型规格, 用于 -□0□ / For "-□0□" Minimum lubrication type >

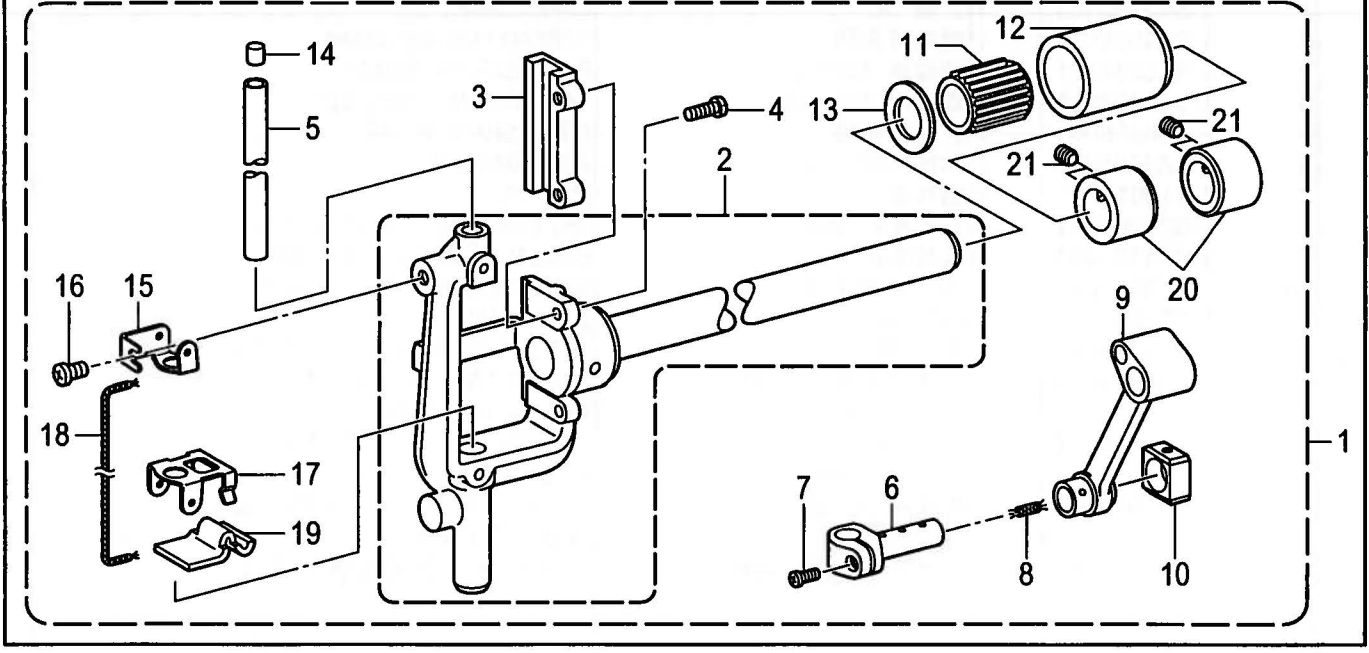

< 针杆无油型规格, 用于 -□3□ / For "-□3□" Semi dry type >

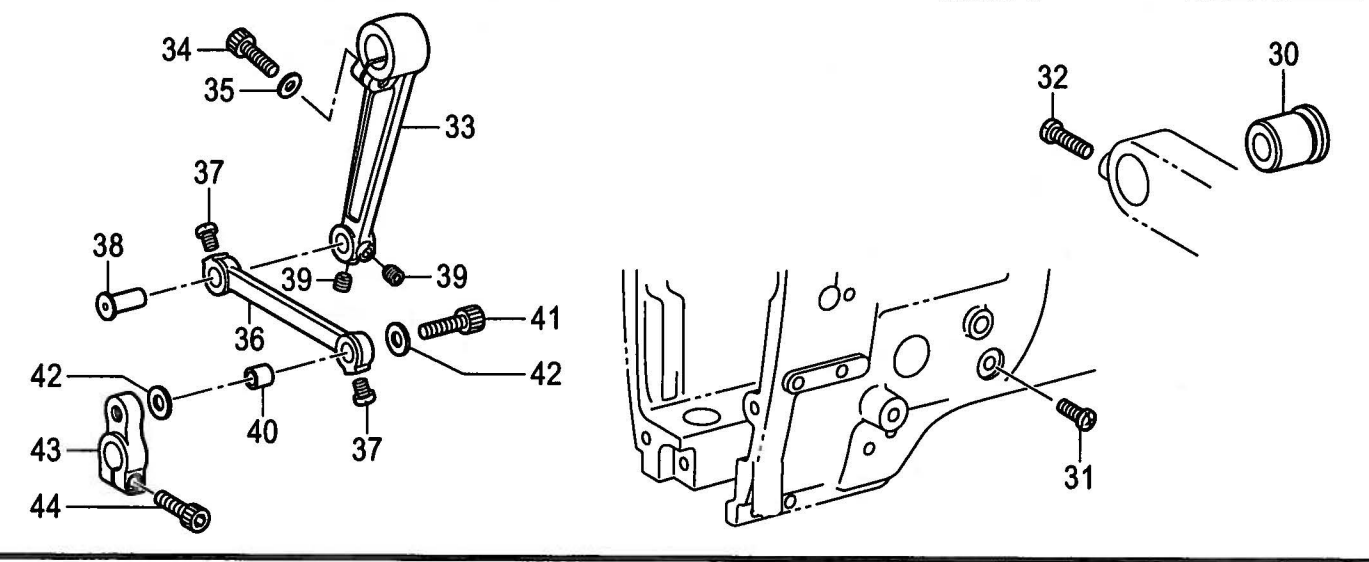
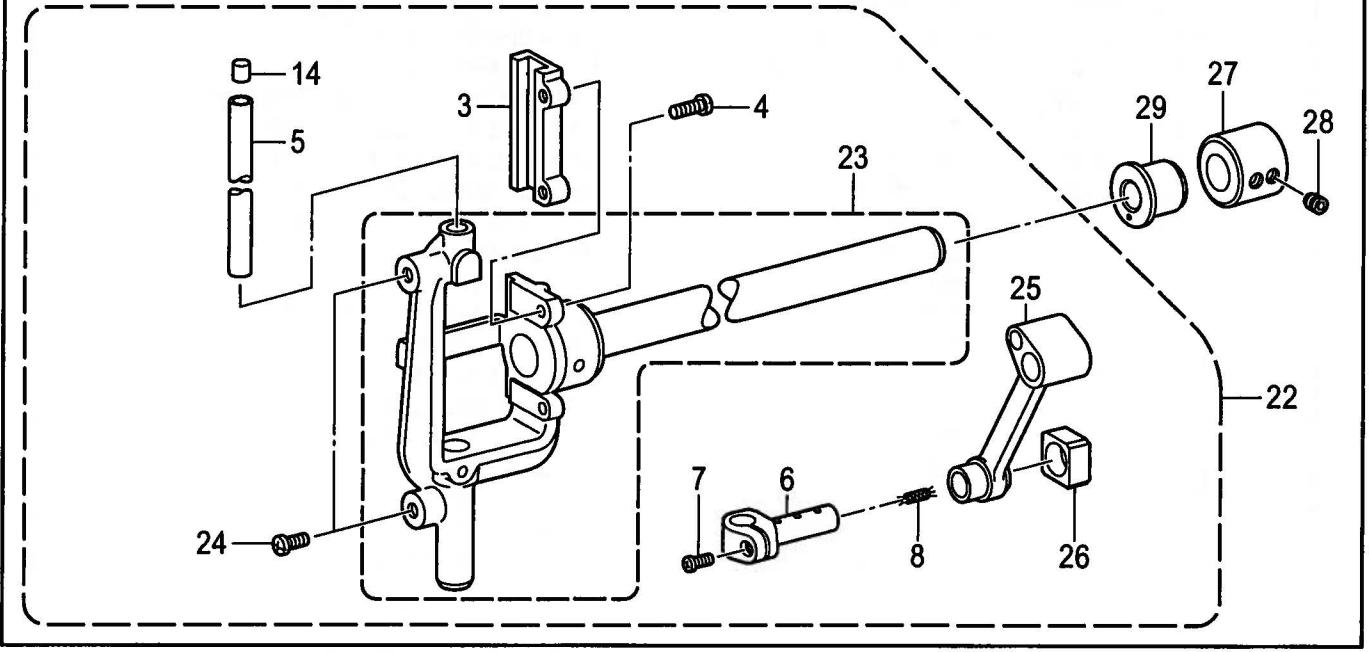

C. 针杆摆动装置 / Needle bar rocking mechanism

参照号	零部件序号	数量	零部件名称	NAME OF PARTS	RM
			<用于-□0□>	<For"-□0□">	
1	SA4124101	1	针杆摆动轴组件	NEEDLE BAR ROCKER SHAFT ASSY	
2	SA3854001	1	针杆台组件	NEEDLE BAR BASE ASSY	
3	SA2474001	1	角滑块槽	SLIDE BLOCK SLIDER	
4	062401016	2	螺钉 M4X10	SCREW, PAN M4X10	
5	SA2475001	1	针杆	NEEDLE BAR	
6	SA3710001	1	针杆抱箍	NEEDLE BAR CLAMP	
7	062350816	1	螺钉 M3.5X8	SCREW, PAN M3.5X8	
8	112728001	1	油线 L=50	WICK, L=50	
9	SA3711001	1	针杆曲柄连杆	CRANK ROD,N-BAR	
10	SA3712001	1	角滑块	SLIDE BLOCK	
11	SA2482001	1	滚针轴承	NEEDLE BEARING	
12	SA2483001	1	轴承套	CASE	
13	SA2484001	1	垫圈	WASHER,PLAIN	
14	148394000	1	针杆塞	CAP, N-BAR	
15	SA4007001	1	油毡上支架 U	FELT SUPPORT, U	
16	062500616	1	螺钉 M5X6	SCREW, PAN M5X6	
17	SA3848001	1	油毡下支架 D	FELT SUPPORT, D	
18	S07465000	1	油线 L=200	WICK, L=200	
19	SA3852001	1	油毡	FELT	
20	SA2485001	2	紧圈	SET SCREW COLLAR	
21	S25260001	4	固定螺钉 M6X5	SET SCREW, SOCKET (FT) M6X5	
			<用于-□3□>	<For"-□3□">	
22	SA4093001	1	针杆摆动轴组件	NEEDLE BAR ROCKER SHAFT ASSY	
23	SA2471001	1	针杆台组件	NEEDLE BAR BASE ASSY	
24	062500816	2	螺钉 M5X8	SCREW, PAN M5X8	
3	SA2474001	1	角滑块槽	SLIDE BLOCK SLIDER	
4	062401016	2	螺钉 M4X10	SCREW, PAN M4X10	
5	SA2475001	1	针杆	NEEDLE BAR	
6	SA3710001	1	针杆抱箍	NEEDLE BAR CLAMP	
7	062350816	1	螺钉 M3.5X8	SCREW, PAN M3.5X8	
8	112728001	1	油线 L=50	WICK, L=50	
25	SA4094001	1	针杆曲柄连杆	CRANK ROD, N-BAR	
26	SA2481001	1	角滑块	SLIDE BLOCK	
14	148394000	1	针杆塞	CAP, N-BAR	
27	SA2485001	1	紧圈	SET SCREW COLLAR	
28	S25260001	2	固定螺钉 M6X5	SET SCREW, SOCKET (FT) M6X5	
29	SA4095001	1	摆动轴轴套 L	BUSH, L	
30	SA2486101	1	摆动轴轴套 R	BUSH, R	
31	062500816	1	螺钉 M5X8	SCREW, PAN M5X8	
32	062061616	1	螺钉 M6X16	SCREW, PAN M6X16	
33	SA2489001	1	针杆摆动连杆	NEEDLE BAR ROCKER LEVER ASSY	
34	018062032	1	螺栓 M6X20	BOLT, SOCKET M6X20	
35	118735002	1	垫圈	WASHER	
36	SA2490101	1	针杆摆动杆	ROCKER LINK, N-BAR	
37	S23460001	2	螺钉 M6X5	SCREW, PAN M6X5	
38	SA4117001	1	摆动杆轴 P	LINK SHAFT, N-BAR ROCKER P	
39	012060636	2	螺钉 M6X6	SET SCREW, SOCKET (FT) M6X6	
40	SA4118001	1	摆动杆轴套 P	ZIGZAG LINK BUSH, P	
41	018062532	1	内六角螺栓 M6X25	BOLT, SOCKET M6X25	
42	SA2493001	2	垫圈	WASHER,PLAIN	
43	SA2494001	1	针杆摆动臂	NEEDLE BAR ROCK ARM	
44	018062032	1	螺栓 M6X20	BOLT, SOCKET M6X20	

D. 压脚装置 / Presser foot mechanism

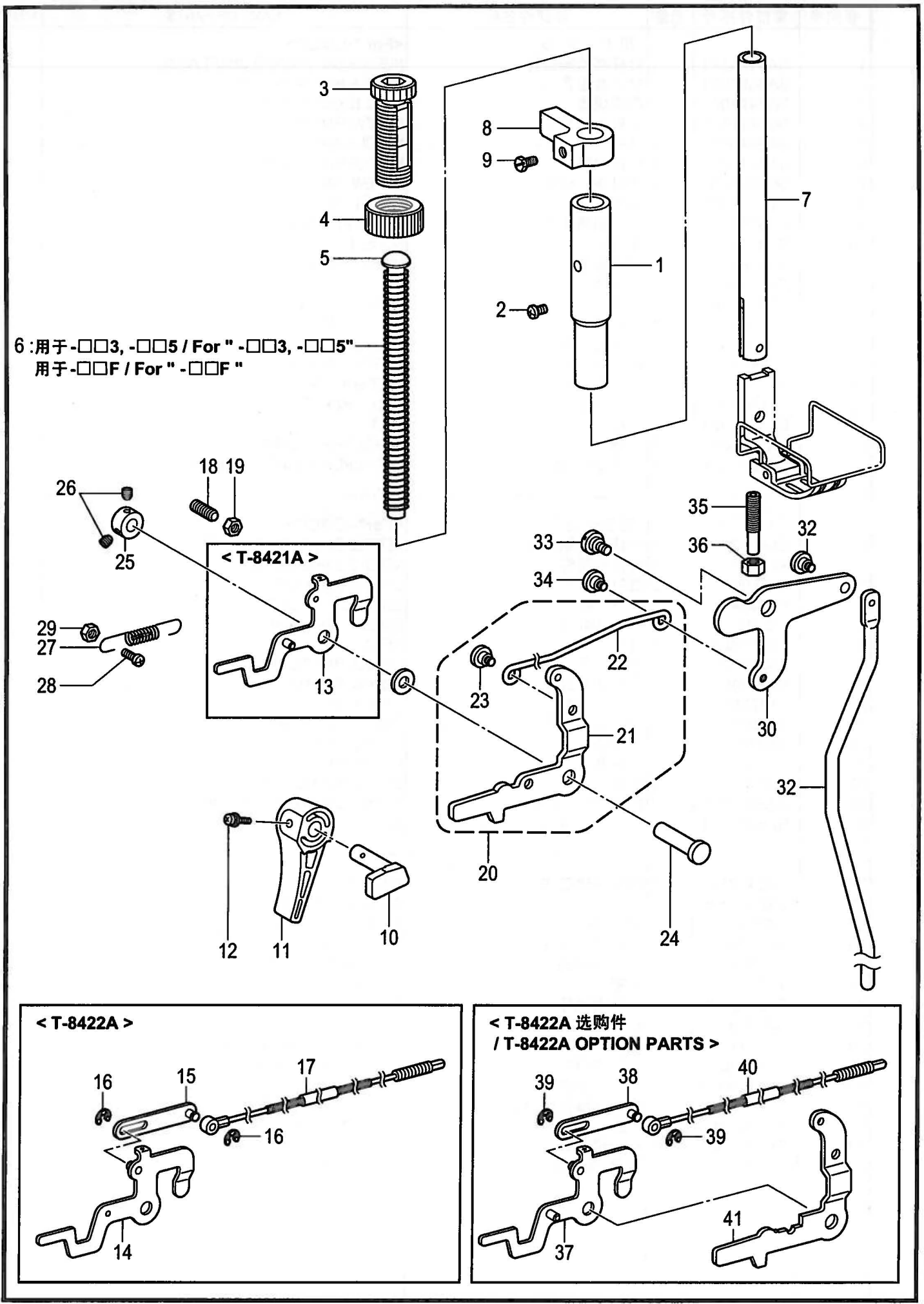

T-8421A/8422A-201

D. 压脚装置 / Presser foot mechanism

参照号	零部件序号	数量	零部件名称	NAME OF PARTS	RM
1	SA2495001	1	压杆轴套	PRESSER BAR BUSH	
2	062500816	1	螺钉 M5X8	SCREW, PAN M5X8	
3	SA1174001	1	调节螺拴 M14	PESSER ADJUSTING SCREW, M14	
4	SA1175001	1	调节螺母 M14	ADJUST SCREW NUT	
5	141208001	1	弹簧导杆	SPRING GUIDE	
6	S07346101	1	<用于-□□3, -□□5> 压紧弹簧	<For"-□□3,-□□5"> PRESSER BAR SPRING, -5	
6	S16196001	1	<用于-□□F用> 压紧弹簧	<For"- □□F"> PRESSER BAR SPRING, F	
7	SA2496001	1	压紧杆	PRESSER BAR	
8	SA2498001	1	压杆抱箍	GUIDE BRACKET, P-BAR	
9	S25289001	1	螺栓 M6X10	BOLT, (CP) M6X10	
10	SA2499001	1	压杆提升曲柄	PRESSER BAR LIFTING CRANK	
11	S31006001	1	抬压脚扳手	LIFTING LEVER	
12	S39051001	1	螺钉(带垫圈)M3.5X12	SCREW, PAN (S/P W) M3.5X12	
13	S07353001	1	<T-8421A> 松线板组件	< T-8421A > TENSION RELEASE PLATE ASSY	
14	S07351001	1	<T-8422A> 松线板组件	< T-8422A > TENSION RELEASE PLATE ASSY	
15	S07529001	1	松线连杆组件	T-RELEASE CONNECTING ROD ASSY	
16	048030342	2	挡圈 E3	RETAINING RING, E3	
17	SA2677001	1	松线电线	TENSION RELEASE WIRE	
18	012061832	1	螺钉 M6X18	SET SCREW, SOCKET (FT) M6X18	
19	021080306	1	螺母 M8	NUT, 3 M8	
20	SA2500001	1	膝控连杆组件	KNEE LIFTER C-ROD ASSY	
21	SA2501001	1	抬压脚连杆	PRESSER BAR LIFTING LEVER	
22	SA2502001	1	膝控连杆	KNEE LIFTER CONNECTING ROD	
23	SA1179001	1	段螺钉 M5	SHOULDER SCREW, M5	
24	S07349001	1	压紧杆提升杠杆销	P-BAR LIFTING LEVER SHAFT	
25	SA2504001	1	紧圈	SET SCREW COLLAR	
26	012500536	2	螺钉 M5X5	SET SCREW, SOCKET (FT) M5X5	
27	S07355051	1	<T-8421A> 弹簧	< T-8421A > SPRING, EXTENSION	
27	S07355051	2	<T-8422A> 弹簧	< T-8422A > SPRING, EXTENSION	
28	062501416	1	螺钉 M5X14	SCREW, PAN M5X14	
29	021500106	1	六角螺母 M5	NUT, 1 M5	
30	SA2506001	1	膝控提升杠杆	KNEE LIFTER LEVER	
31	SA2507001	1	膝控提升杆	KNEE LIFTER BAR	
32	SA1179001	1	段螺钉 M5	SHOULDER SCREW, M5	
33	SA2165001	1	段螺钉 M6	SHOULDER SCREW, M6	
34	SA1179001	1	段螺钉 M5	SHOULDER SCREW, M5	
35	SA4149001	1	调整螺钉 6	ADJUSTING SCREW, 6	
36	021060306	1	六角螺母 M6	NUT, 3 M6	
37	S10780001	1	< T-8422A 选购件 > 松线板组件	< T-8422A OPTION PARTS > TENSION RELEASE PLATE ASSY	
38	S07529001	1	松线连杆组件	T-RELEASE CONNECTING ROD ASSY	
39	048030342	2	挡圈 E3	RETAINING RING, E3	
40	SA2677001	1	松线电线	TENSION RELEASE WIRE	
41	SA2578001	1	抬压脚连杆	PRESSER BAR LIFTING LEVER	

E. 送布装置 / Feed mechanism

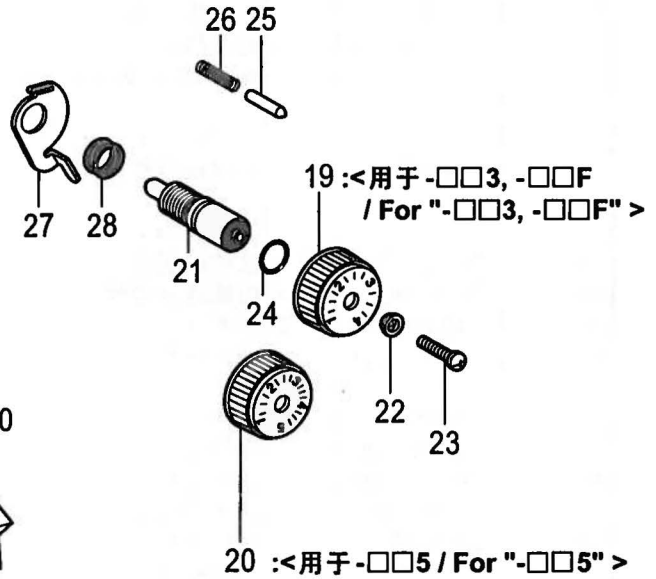
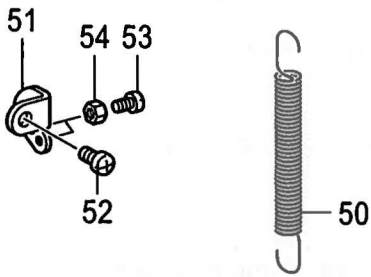
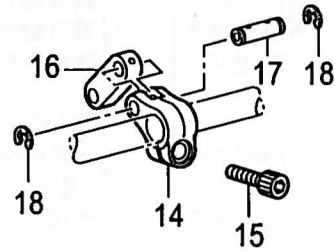
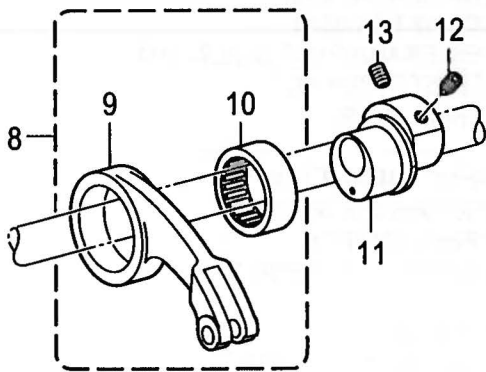

1 : <用于-□□3, -□□F / For "-□□3, -□□F" >
 <用于-□□5 / For "-□□5" >

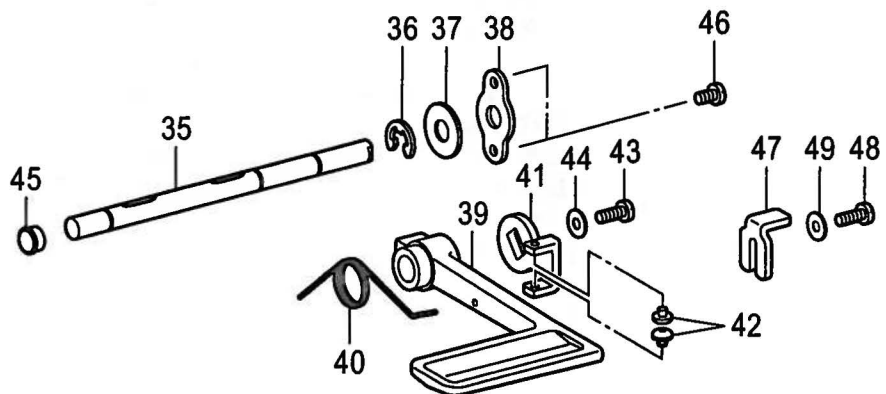
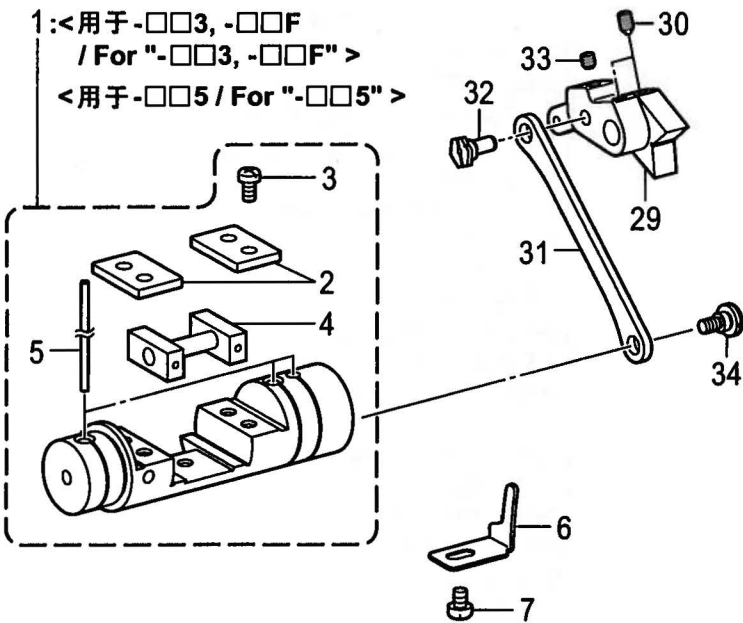

E. 送布装置 / Feed mechanism

参照号	零部件序号	数量	零部件名称	NAME OF PARTS	RM
1	SA3062001	1	<用于-□□3, -□□F> 切换器11组件	<For"-□□3,-□□F"> FEED REGULATOR ASSY, 11	
1	SA2509001	1	<用于-□□5> 切换器组件	<For"-□□5"> FEED REGULATOR ASSY	
2	SA2511001	2	滑块导向	GUIDE PLATE	
3	062501016	4	螺钉 M5X10	SCREW, PAN M5X10	
4	SA2512001	1	滑块组件	SLIDE BLOCK ASSY	
5	SA2515001	3	油毡	FELT	
6	SA2516001	1	切换器定位	STOPEER	
7	062060816	1	螺钉 M6X8	SCREW, PAN M6X8	
8	143611201	1	送布连杆组件	F-ROCKER CONNECTING ROD ASSY	
9	143612100	1	送布大连杆	FEED ROCKER CONNECTING ROD	
10	118954000	1	滚针轴承	NEEDLE BEARING	
11	SA2518001	1	水平偏心轮 5	LEVEL FEED ECCENTRIC WHEEL 5	
12	SA2585001	1	固定螺钉 M6X10	SET SCREW, SOCKET (FT) M6	
13	S25236001	1	螺钉 M6X10	SET SCREW, SOCKET (FT) M6X10	
14	SA2521001	1	水平送料臂 5	FEED ROCKER ARM 5	
15	018062032	1	螺栓 M6X20	BOLT, SOCKET M6X20	
16	143613051	1	送布小连杆	LINK	
17	143616001	1	送布曲柄轴	SHAFT	
18	048060342	2	挡圈 E6	RETAINING RING, E6	
19	S38422001	1	<用于-□□3, -□□F> 针距标盘	<For"-□□3,-□□F"> STITCH LENGTH DIAL, 4	
20	S38427001	1	<用于-□□5> 针距标盘	<For"-□□5"> STITCH LENGTH DIAL, 5	
21	SA3056001	1	调节螺栓	FEED REGULATING STUD	
22	142746002	1	针距标盘套	FEED REGULATING SUPPORTER	
23	129458102	1	螺钉 SM4.76	SCREW, SM4.76	
24	108549001	1	O形圈	O RING	
25	S50098101	1	定位销	POSITIONING PIN	
26	100328001	1	止动销弹簧	NOTCH SPRING	
27	SA2523001	1	标盘锁杆	DIAL LOCK LEVER	
28	S39830101	1	弹簧	SPRING	
29	SA2525001	1	送料调节器 5	FEED REGULATOR 5	
30	016061031	2	螺钉 M6X10	SET SCREW, SOCKET (CN) M6X10	
31	SA2526001	1	切换器连杆	CONNECTING ROD	
32	SA2527001	1	偏心轴	ECCENTRIC SHAFT	
33	012060636	1	螺钉 M6X6	SET SCREW, SOCKET (FT) M6X6	
34	SA2528101	1	段螺钉 M6	SHOULDER SCREW, M6	
35	SA2529001	1	倒缝手柄轴 TR	SHAFT, R-LEVER TR	
36	048080342	1	挡圈 E8	RETAINING RING, E8	
37	025100132	1	平垫圈 S10	WASHER, PLAIN S 10	
38	SA2530001	1	垫片	SPACER	
39	S07374109	1	倒缝扳手	REVERSE STITCHING LEVER	
40	SA2531001	1	弹簧	SPRING	
41	SA3067001	1	手柄导向	LEVER GUIDE	
42	S48367000	2	导向橡皮	RUBBER	
43	062501216	1	螺钉 M5X12	SCREW, PAN M5X12	
44	025050336	1	平垫圈 L5	WASHER, PLAIN L 5	
45	104821001	1	橡皮塞 10.5	RUBBER CAP, 10.5	
46	062500816	2	螺钉 M5X8	SCREW, PAN M5X8	
47	SA2532001	1	定位器	STOPPER	
48	062501216	1	螺钉 M5X12	SCREW, PAN M5X12	
49	025050236	1	平垫圈 M5	WASHER, PLAIN M 5	
50	S07376001	1	调节器弹簧	FEED REGULATOR SPRING	
51	SA2533001	1	弹簧挂钩	SPRING HOOK	
52	062060816	1	螺钉 M6X8	SCREW, PAN M6X8	
53	062501216	1	螺钉 M5X12	SCREW, PAN M5X12	
54	021500106	1	六角螺母 M5	NUT, 1 M5	

F. 倒缝装置 / Quick reverse mechanism

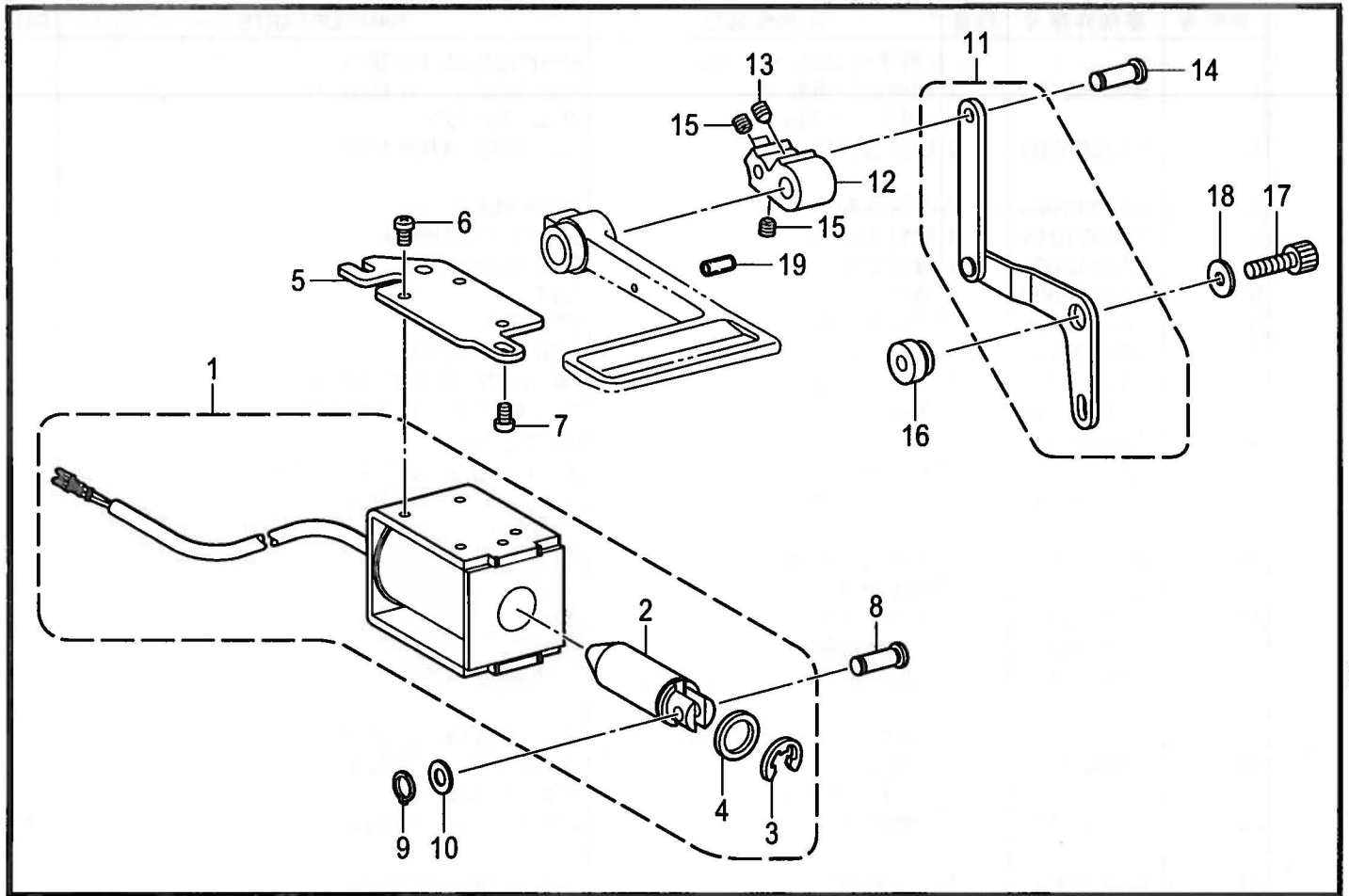

T-8421A/8422A-205

G. 倒缝开关装置 / Quick reverse switch mechanism

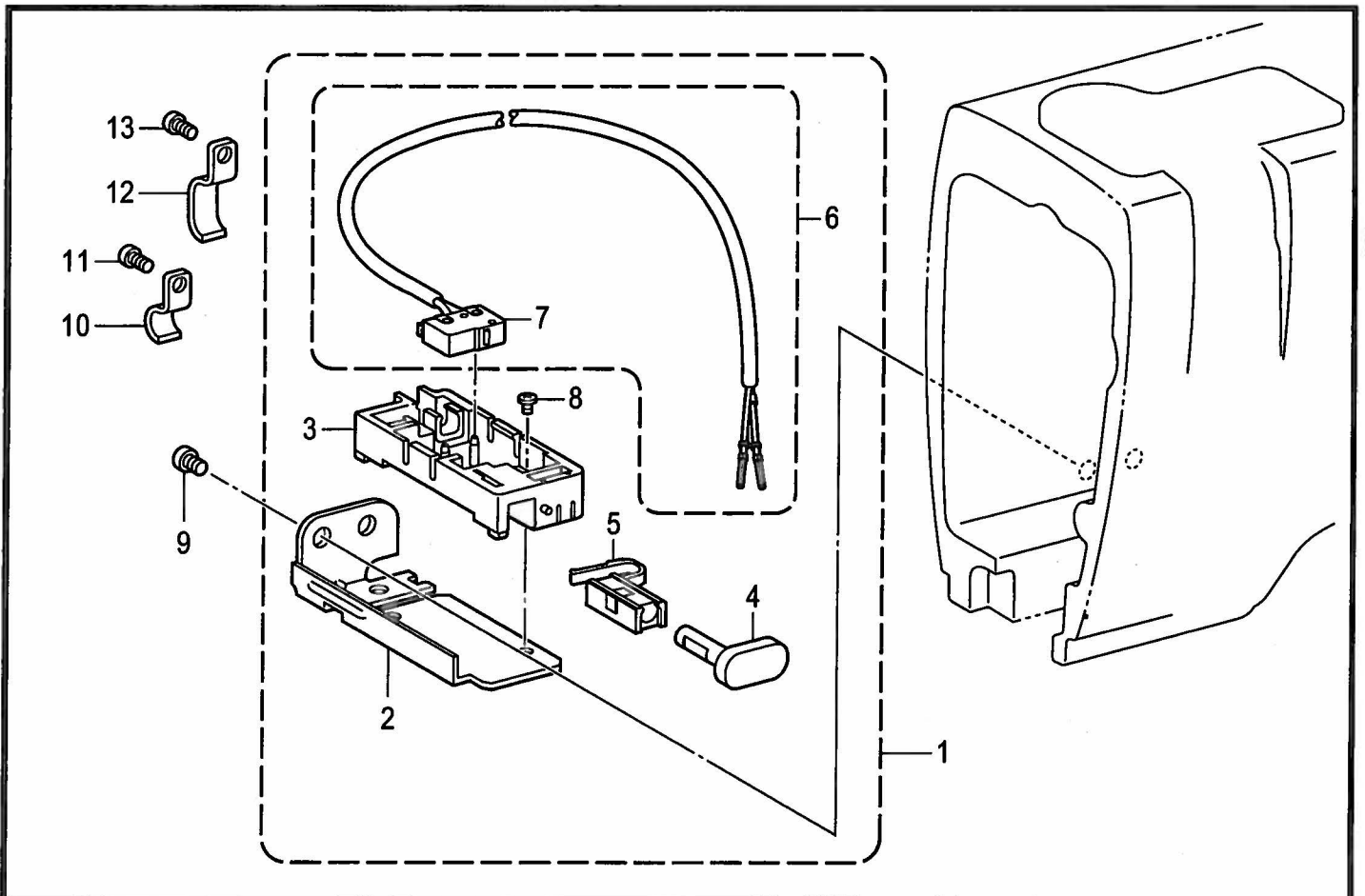

T-8421A/8422A-508

F. 倒缝装置 / Quick reverse mechanism

参照号	零部件序号	数量	零部件名称	NAME OF PARTS	RM
1	SA3072001	1	反转电磁铁组件	QUICK REVERSE SOLENOID ASSY	
2	154729001	1	柱塞	PLUNGER	
3	154730001	1	挡圈 E15	RETAINING RING, E15	
4	154731000	1	橡胶垫	RUBBER STOPPER	
5	SA2535101	1	电磁铁基座	SOLENOID BRACKET	
6	062500812	3	螺钉 M5X8	SCREW, PAN M5X8	
7	062061016	2	螺钉 M6X10	SCREW, PAN M6X10	
8	SA2992001	1	连接销	PIN	
9	048060142	1	轴用挡圈 C6	RETAINING RING, EXTERNAL C6	
10	153138001	1	垫圈 6.5	WASHER, PLAIN 6.5	
11	SA2536001	1	电磁铁曲杆组件	SOLENOID LEVER ASSY	
12	SA2540001	1	反转曲柄	QUICK REVERSE LEVER	
13	016061031	2	螺钉 M6X10	SET SCREW, SOCKET (CN) M6X10	
14	SA2992001	1	连接销	PIN	
15	012060636	2	螺钉 M6X6	SET SCREW, SOCKET (FT) M6X6	
16	SA2539001	1	电磁铁曲杆轴	SOLENOID LEVER SHAFT	
17	018062032	1	螺栓 M6X20	BOLT, SOCKET M6X20	
18	149095001	1	垫圈 6	WASHER, PLAIN 6	
19	153132000	1	尼龙管 L=13.5	NYLON TUBE, L=13.5	

T-8421A/8422A-205

G. 倒缝开关装置 / Quick reverse switch mechanism

参照号	零部件序号	数量	零部件名称	NAME OF PARTS	RM
1	SA2688001	1	调节器按钮组件	REVERSE ACTUATOR ASSY	
2	SA2270001	1	倒缝开关安装架	REVERSE SWITCH BRACKET	
3	S34281000	1	倒缝开关基体	REVERSE SWITCH BRACKET	
4	S32904000	1	按钮	ACTUATOR	
5	S32905000	1	R-开关弹簧	REVERSE SWITCH SPRING	
6	SA1390001	1	R开关组件	R-SWITCH ASSY	
7	S32907000	1	微动开关	MICRO SWITCH	
8	060300606	1	螺钉 M3X6	SCREW, BIND M3X6	
9	062500616	2	螺钉 M5X6	SCREW, PAN M5X6	
10	SA2689001	1	线夹	CORD HOLDER	
11	062500616	1	螺钉 M5X6	SCREW, PAN M5X6	
12	SA1388001	3	线夹	CORD HOLDER	
13	062500616	1	螺钉 M5X6	SCREW, PAN M5X6	

T-8421A/8422A-508

H. 送布轴装置 / Feed shaft mechanism

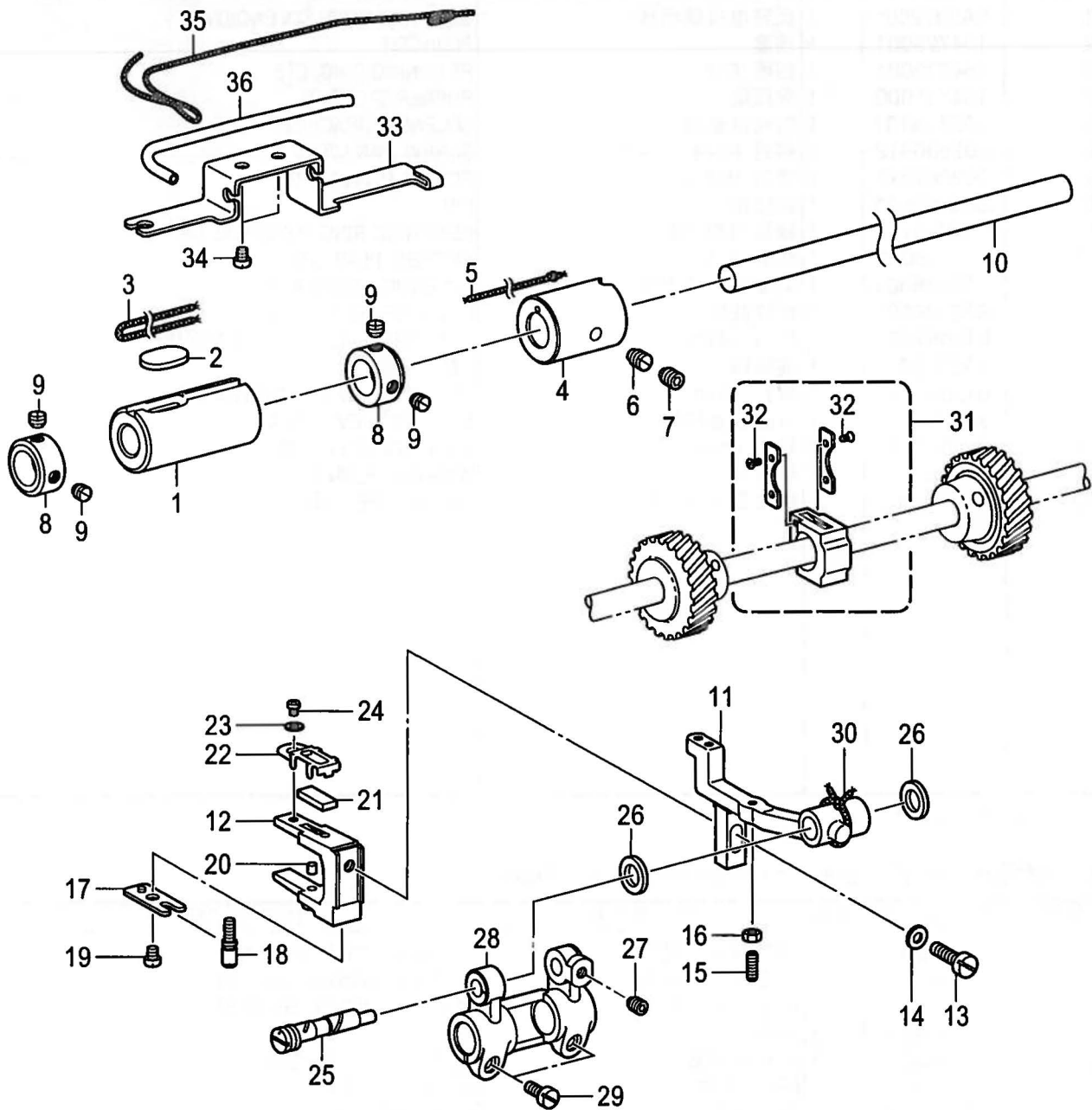

" 选购件 / OPTION PARTS " < 无油型规格 / Dry Type >

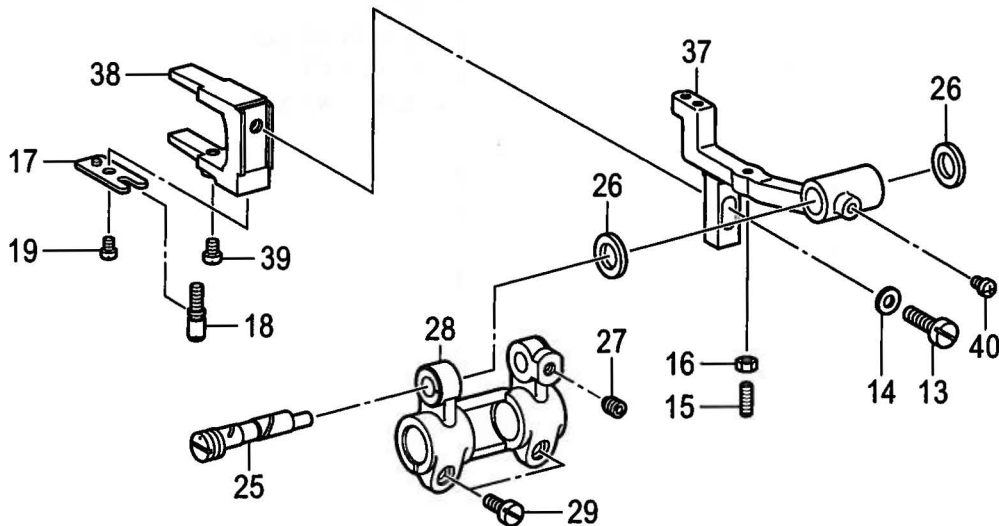

H. 送布轴装置 / Feed shaft mechanism

参照号	零部件序号	数量	零部件名称	NAME OF PARTS	RM
1	SA3855001	1	送布轴套 L	BUSH,L,F-ROCKER SHAFT	
2	SA3965001	1	油毡	FELT	
3	SA4028001	1	油线 4X4 L=220	WICK, 4X4 L=220	
4	SA2543001	1	送布轴套 R	FEED ROCKER SHAFT BUSH, R	
5	108802001	1	油线 4X4 L=250	WICK, 4X4 L=250	
6	SA2544001	1	螺钉 M6	SET SCREW M6	
7	012060636	1	螺钉 M6X6	SET SCREW, SOCKET (FT) M6X6	
8	SA2546001	2	紧圈	SET SCREW COLLAR	
9	S23651001	4	固定螺钉 M6X6	SET SCREW, SOCKET (FT) M6X6	
10	SA3840001	1	送布轴	FEED ROCKER SHAFT	
			<T-8421A>	< T-8421A >	
11	SA3864001	1	送布台 ST	FEED BAR,ST	
			<T-8422A>	< T-8422A >	
11	SA3867001	1	送布台 TR	FEED BAR,TR	
12	SA3886001	1	送布台叉	FEED BAR FORK	
13	SA2927001	1	螺钉 M6X14	SCREW, M6X14	
14	025060132	1	平垫圈 S6	WASHER, PLAIN S 6	
15	SA2566001	1	螺钉 M3.5	SET SCREW, M3.5	
16	021350106	1	螺母 M3.5	NUT, 1 M3.5	
17	SA2553001	1	开叉板	FORKED PLATE	
18	SA2554001	1	调整螺栓	ADJUSTING SCREW ,HIGHT	
19	062400616	1	螺钉 M4X6	SCREW, PAN M4X6	
20	SA3990001	1	油毡	FELT	
21	SA3887001	1	油毡	FELT	
22	SA3888001	1	油毡压架	FELT HOLDER	
23	025030132	1	平垫圈 S3	WASHER, PLAIN S 3	
24	062300416	1	螺钉 M3X4	SCREW, PAN M3X4	
25	SA2550001	1	送布台安装轴	FEED BAR SHAFT	
26	SA2551001	2	轴向垫圈	THRUST RING	
27	012060636	1	螺钉 M6X6	SET SCREW, SOCKET (FT) M6X6	
28	SA2555001	1	水平送布台臂	FEED ROCKER BASE ARM	
29	SA2928001	2	螺钉 M5X12	SCREW, M5X12	
30	SA4025001	1	油线 4X4 L=180	WICK, 4X4 L=180	
31	SA2806001	1	角滑块组件	FEED BAR SLIDE BLOCK ASSY	
32	W01519001	4	螺钉(#0) M2X4	SCREW, FLAT #0 M2X4	
33	SA4009001	1	油线支架	WICK SUPPORT	
34	062400616	2	螺钉 M4X6	SCREW, PAN M4X6	
35	SA2724001	1	油线 L=400	WICK, L=400	
36	SA4011001	1	维尼龙油管 L=100	OIL TUBE, L=100	
			<选购件>用于无油型规格	<OPTION PARTS>Dry Type	
			<T-8421A>	< T-8421A >	
37	SA2754001	1	送布台 ST	FEED BAR, ST	
			<T-8422A>	< T-8422A >	
37	SA2549001	1	送布台 TR	FEED BAR, TR	
38	SA2552001	1	送布台叉	FEED BAR FORK	
39	062500816	1	螺钉 M5X8	SCREW, PAN M5X8	
40	062500616	1	螺钉 M5X6	SCREW, PAN M5X6	

J1. 旋梭装置(T-8421A) / Rotary hook mechanism (T-8421A)

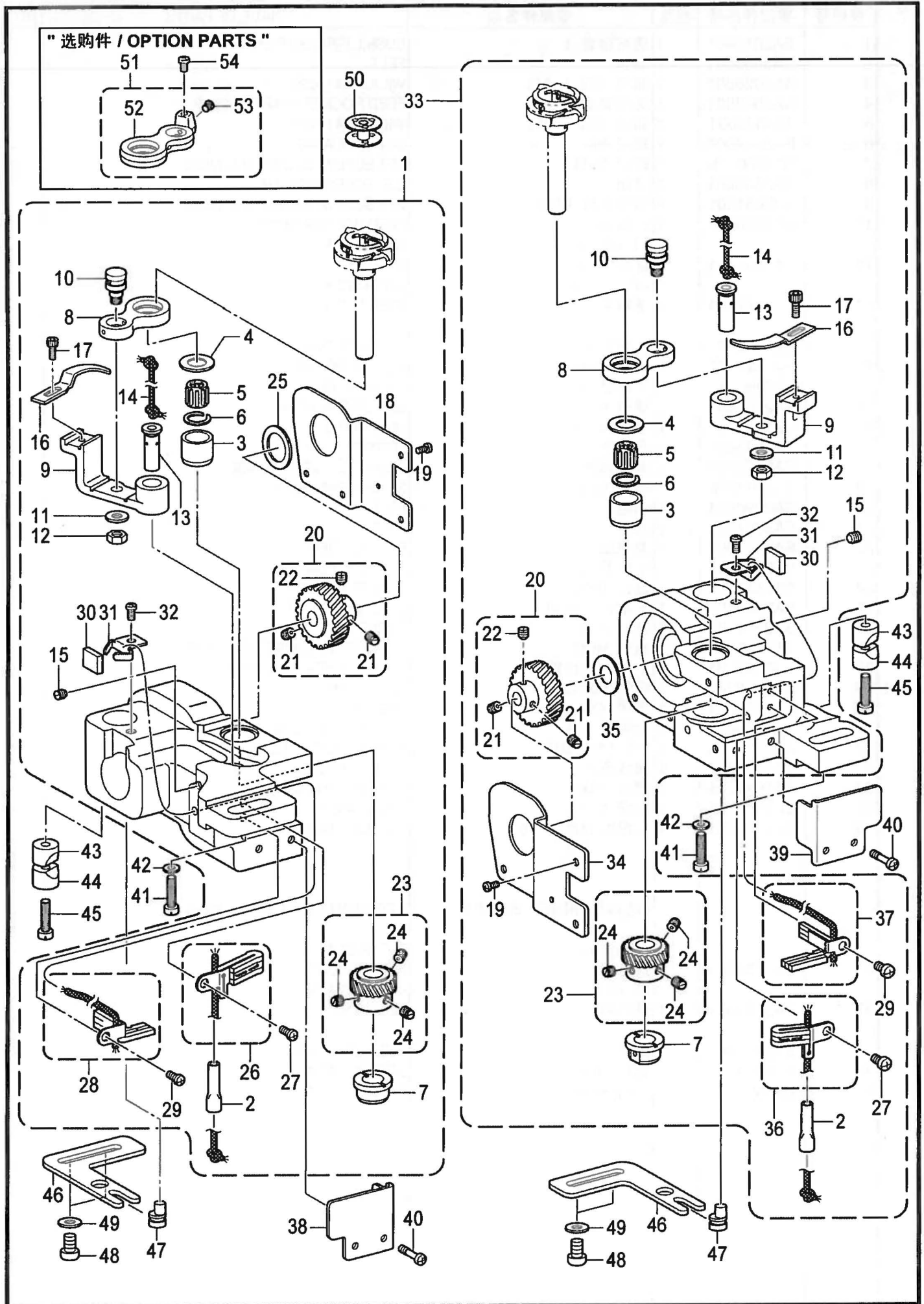

T-8421A-301

J1 . 旋梭装置(T-8421A) / Rotary hook mechanism (T-8421A)

参照号	零部件序号	数量	零部件名称	NAME OF PARTS	RM
1	SA2755101	1	<用于-□3,-□□F> 旋梭基座组件 842ST(L)	<For"-□□3,-□□F"> ROTARY HOOK BASE ASSY,842ST(L)	
1	SA2950101	1	<用于-□□5> 旋梭基座组件 842ST-5L	<For"-□□5"> ROTARY HOOK BASE ASSY,842ST-5L	
2	SA3961001	1	管	PIPE	
3	SA4029001	1	旋梭轴套 U	ROTARY HOOK SHAFT BUSH	
4	S09260001	1	轴向垫圈 A <t=1.2>	THRUST RING, A :1.2MM< t=1.2 >	
4	SA4038001	1	轴向垫圈 <t=1.0>	THRUST RING< t=1.0 >	
4	S09261001	1	轴向垫圈 B <t=1.4>	THRUST RING, B :1.4MM< t=1.4 >	
5	S07420000	1	滚针轴承	NEEDLE BEARING	
6	S07419001	1	止动圈	RETAINING RING	
7	SA2557001	1	旋梭轴套 D	ROTARY HOOK SHAFT BUSH	
8	SA3856001	1	分线钩连杆	OPENER LINK	
9	SA3859001	1	分线钩杆	OPENER LEVER	
10	SA2560001	1	分线钩连杆轴	SHAFT, O-LINK	
11	025710132	1	平垫圈 S4.76	WASHER,PLAIN S 4.76	
12	021500316	1	六角螺母 M5	NUT, 3 M5	
13	SA3889001	1	分线钩杆短轴	O-LEVER SHAFT	
14	SA4026001	1	油线 4X4 L=100	WICK, 4X4 L=100	
15	012500536	1	螺钉 M5X5	SET SCREW, SOCKET (FT) M5X5	
16	S38212001	1	分线钩	OPENER	
17	154965001	1	螺钉 SM3.57X8	BOLT, SOCKET SM3.57X8	
18	SA2562101	1	旋梭基座盖 L	ROTARY HOOK BASE COVER, L	
19	062300612	4	螺钉 M3X6	SCREW, PAN M3X6	
20	SA2572001	1	螺旋齿轮(带螺钉)	SPIRAL GEAR SCREW ASSY	
21	SA2574001	2	螺钉 M6	SET SCREW, (FT) M6	
22	SA2575001	1	螺钉 M6	SET SCREW, (FT) M6	
23	SA2576001	1	人字齿轮组件	PINION GEAR SCREW ASSY	
24	SA2575001	3	螺钉 M6	SET SCREW, (FT) M6	
25	SA3054001	1	垫圈 L	THRUST WASHER, L	
26	SA4042001	1	油毡组件 UL	FELT UL ASSY	
27	062400616	1	螺钉 M4X6	SCREW, PAN M4X6	
28	SA4044001	1	油毡组件 DL	FELT DL ASSY	
29	062400616	1	螺钉 M4X6	SCREW, PAN M4X6	
30	SA4012001	1	油毡	FELT	
31	SA3894001	1	油毡架	FELT SUPPORT	
32	062400616	1	螺钉 M4X6	SCREW, PAN M4X6	
33	SA2757101	1	<用于-□3,-□□F> 旋梭基座组件 842ST(R)	<For"-□□3,-□□F"> ROTARY HOOK BASE ASSY,842ST(R)	
33	SA2951101	1	<用于-□□5> 旋梭基座组件 842ST-5L	<For"-□□5"> ROTARY HOOK BASE ASSY,842ST-5R	
2	SA3961001	1	管	PIPE	
3	SA4029001	1	旋梭轴套 U	ROTARY HOOK SHAFT BUSH	
4	S09260001	1	轴向垫圈 A 1.2MM	THRUST RING, A :1.2MM< t=1.2 >	
4	SA4038001	1	轴向垫圈 1.0MM	THRUST RING< t=1.0 >	
4	S09261001	1	轴向垫圈 B 1.4MM	THRUST RING, B :1.4MM< t=1.4 >	
5	S07420000	1	滚针轴承	NEEDLE BEARING	
6	S07419001	1	止动圈	RETAINING RING	
7	SA2557001	1	旋梭轴套 D	ROTARY HOOK SHAFT BUSH	
8	SA3856001	1	分线钩连杆	OPENER LINK	
9	SA3859001	1	分线钩杆	OPENER LEVER	
10	SA2560001	1	分线钩连杆轴	SHAFT, O-LINK	
11	025710132	1	平垫圈 S4.76	WASHER,PLAIN S 4.76	
12	021500316	1	六角螺母 M5	NUT, 3 M5	
13	SA3889001	1	分线钩杆短轴	O-LEVER SHAFT	
14	SA4026001	1	油线 4X4 L=100	WICK, 4X4 L=100	
15	012500536	1	螺钉 M5X5	SET SCREW, SOCKET (FT) M5X5	
16	S38212001	1	分线钩	OPENER	
17	154965001	1	螺钉 SM3.57X8	BOLT, SOCKET SM3.57X8	

J1 . 旋梭装置 (T-8421A) / Rotary hook mechanism (T-8421A)

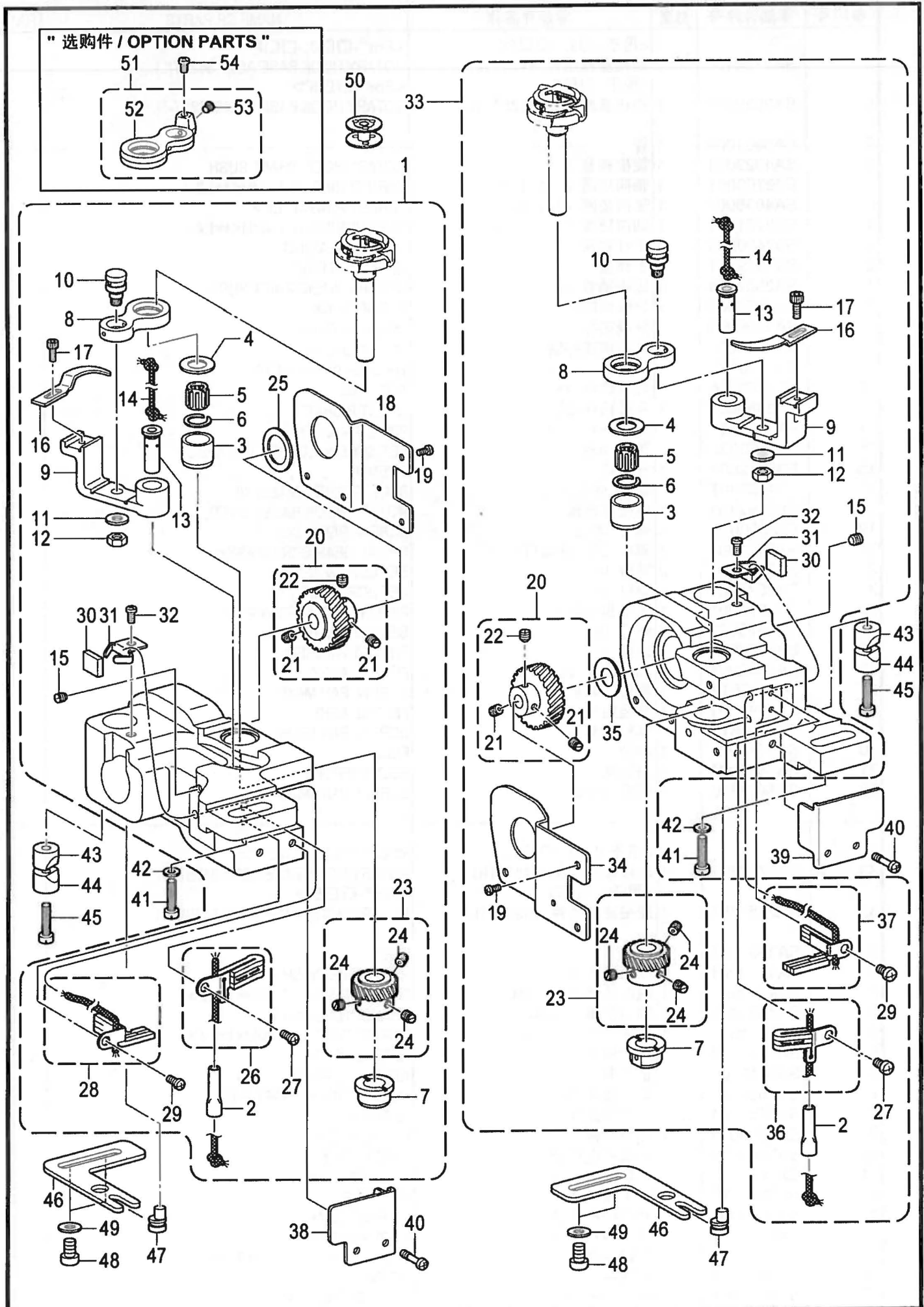

T-8421A-301

J1 . 旋梭装置(T-8421A) / Rotary hook mechanism (T-8421A)

参照号	零部件序号	数量	零部件名称	NAME OF PARTS	RM
34	SA2563101	1	旋梭基座盖 R	ROTARY HOOK BASE COVER, R	
19	062300612	4	螺钉 M3X6	SCREW, PAN M3X6	
20	SA2572001	1	螺旋齿轮(带螺钉)	SPIRAL GEAR SCREW ASSY	
21	SA2574001	2	螺钉 M6	SET SCREW, (FT) M6	
22	SA2575001	1	螺钉 M6	SET SCREW, (FT) M6	
23	SA2576001	1	人字齿轮组件	PINION GEAR SCREW ASSY	
24	SA2575001	3	螺钉 M6	SET SCREW, (FT) M6	
35	SA2579001	1	垫圈	SPECER	
36	SA4043001	1	油毡组件 UR	FELT UR ASSY	
27	062400616	1	螺钉 M4X6	SCREW, PAN M4X6	
37	SA4045001	1	油毡组件 DR	FELT DR ASSY	
29	062400616	1	螺钉 M4X6	SCREW, PAN M4X6	
30	SA4012001	1	油毡	FELT	
31	SA3894001	1	油毡架	FELT SUPPORT	
32	062400616	1	螺钉 M4X6	SCREW, PAN M4X6	
<hr/>					
38	SA3988001	1	旋梭基座盖 FL	ROTARY HOOK BASE COVER, FL	
39	SA3916001	1	旋梭基座盖 FR	ROTARY HOOK BASE COVER, FR	
40	SA2825001	4	螺钉 M3X12	SCREW, M3X12	
41	SA2556001	2	螺钉 M6X25	SCREW, M6X25	
42	115947001	2	垫圈 6.35	WASHER, PLAIN 6.35	
43	SA2722001	2	套管 A	PINCH SLEEVE A	
44	SA2565001	2	套管 B	PINCH SLEEVE B	
45	SA2556001	2	螺钉 M6X25	SCREW, M6X25	
46	SA2567001	2	调节板	NEEDLE UPPER POSITIONING PLATE	
47	SA2568001	2	调节轴	NEEDLE UPPER POSITIONING SHAFT	
48	062061016	4	螺钉 M6X10	SCREW, PAN M6X10	
49	025060136	4	平垫圈 S6	WASHER, PLAIN S 6	
50	S01928151	2	梭芯	BOBBIN	
51	SA2827001	2	<选购件>用于无油型规格 分线钩连杆组件	<OPTION PARTS>For dry type OPENER LINK ASSY	
52	SA2558001	2	分线钩连杆	OPENER LINK	
53	S58900000	2	螺钉 M2	SCREW, M2	
54	062400416	2	螺钉 M4X4	SCREW, PAN M4X4	

" 选购件 / OPTION PARTS "

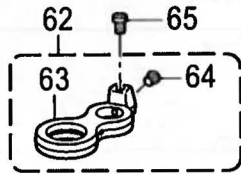

" 选购件 / OPTION PARTS "

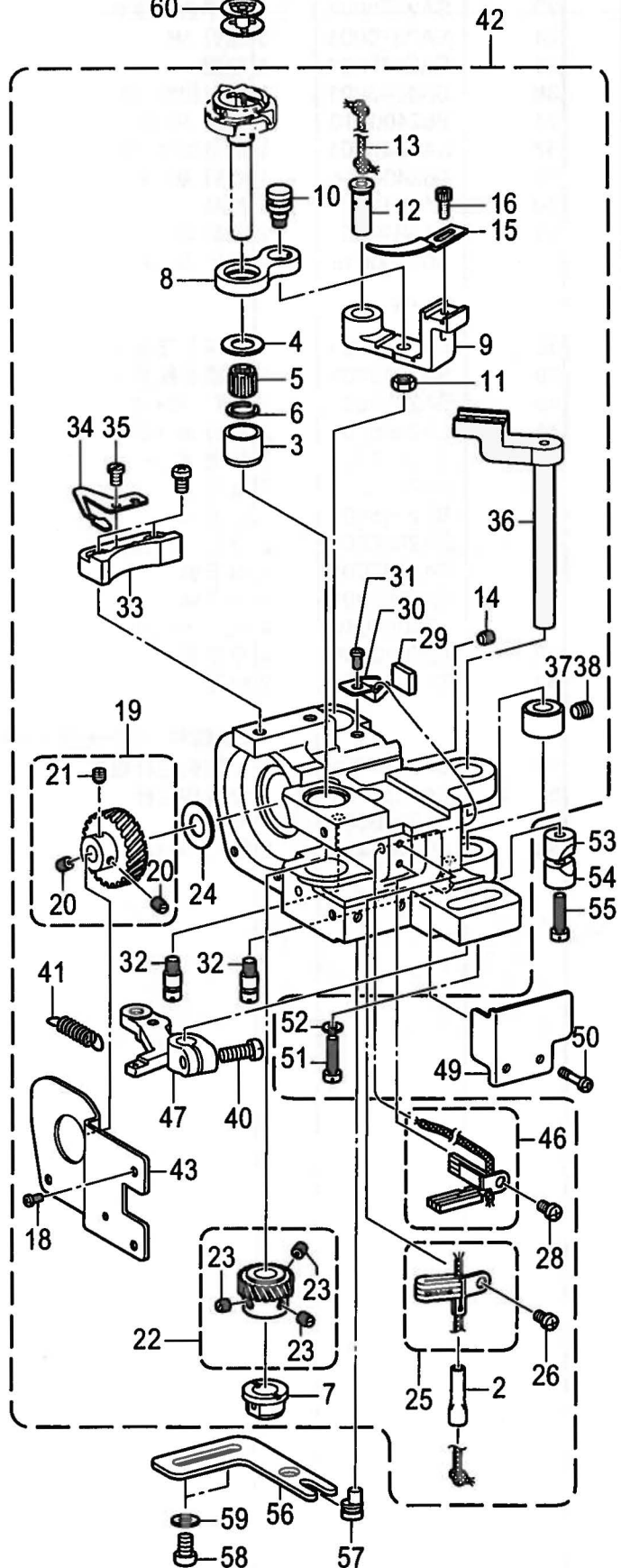
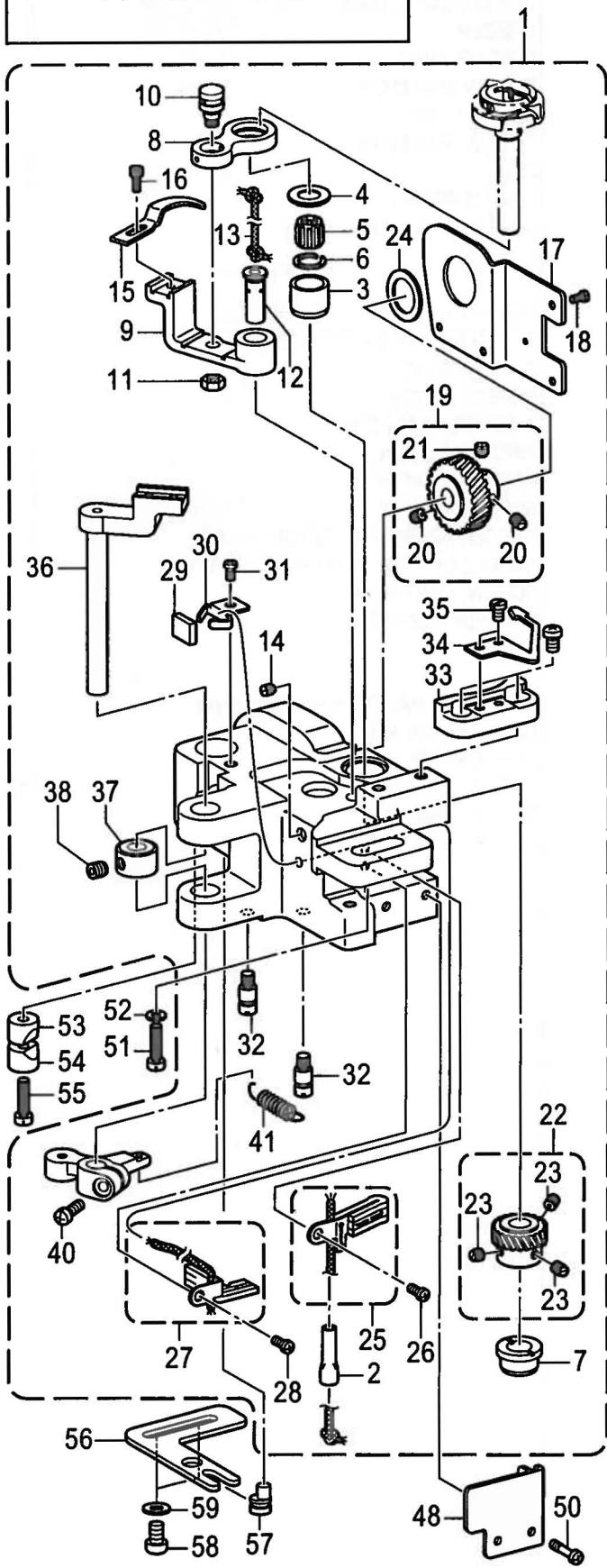
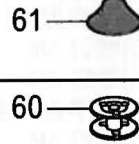

J2 . 旋梭装置(T-8422A) / Rotary hook mechanism (T-8422A)

	零部件序号	数量	零部件名称	NAME OF PARTS	RM
1	SA3953001	1	旋梭基座 842TR(L)	ROTARY HOOK BASE,842TR(L)	
2	SA3961001	1	管	PIPE	
3	SA4029001	1	旋梭轴套 U	ROTARY HOOK SHAFT BUSH	
4	S09260001	1	轴向垫圈 A 1.2MM	THRUST RING, A :1.2MM< t=1.2 >	
4	SA4038001	1	轴向垫圈 1.0MM	THRUST RING< t=1.0 >	
4	S09261001	1	轴向垫圈 B 1.4MM	THRUST RING, B :1.4MM< t=1.4 >	
5	S07420000	1	滚针轴承	NEEDLE BEARING	
6	S07419001	1	止动圈	RETAINING RING	
7	SA2557001	1	旋梭轴套 D	ROTARY HOOK SHAFT BUSH	
8	SA3856001	1	分线钩连杆	OPENER LINK	
9	SA3859001	1	分线钩杆	OPENER LEVER	
10	SA2560001	1	分线钩连杆轴	SHAFT, O-LINK	
11	021500316	1	六角螺母 M5	NUT, 3 M5	
12	SA3889001	1	分线钩杆短轴	O-LEVER SHAFT	
13	SA4026001	1	油线 4X4 L=100	WICK, 4X4 L=100	
14	012500536	1	螺钉 M5X5	SET SCREW, SOCKET (FT) M5X5	
15	S38212001	1	分线钩	OPENER	
16	154965001	1	螺钉 SM3. 57X8	BOLT, SOCKET SM3.57X8	
17	SA2562101	1	旋梭基座盖 L	ROTARY HOOK BASE COVER, L	
18	062300612	4	螺钉 M3X6	SCREW, PAN M3X6	
19	SA2572001	1	螺旋齿轮(带螺钉)	SPIRAL GEAR SCREW ASSY	
20	SA2574001	2	螺钉 M6	SET SCREW, (FT) M6	
21	SA2575001	1	螺钉 M6	SET SCREW, (FT) M6	
22	SA2576001	1	人字齿轮组件	PINION GEAR SCREW ASSY	
23	SA2575001	3	螺钉 M6	SET SCREW, (FT) M6	
24	SA3054001	1	垫圈 L	THRUST WASHER, L	
25	SA4042001	1	油毡组件 UL	FELT UL ASSY	
26	062400616	1	螺钉 M4X6	SCREW, PAN M4X6	
27	SA4044001	1	油毡组件 DL	FELT DL ASSY	
28	062400616	1	螺钉 M4X6	SCREW, PAN M4X6	
29	SA4012001	1	油毡	FELT	
30	SA3894001	1	油毡架	FELT SUPPORT	
31	062400616	1	螺钉 M4X6	SCREW, PAN M4X6	
32	SA2717001	2	定位螺钉	STOPPER SCREW	
33	SA2676001	1	动刀座	MOVABLE KNIFE BRACKET	
34	S07525000	1	板弹簧	SPRING, PLATE	
35	141544001	2	螺钉 SM3. 18-40X3	SCREW, SM3.18-40X3	
36	SA3912001	1	动刀杆	MOVABLE KNIFE LEVER	
37	SA2675001	1	紧圈	SET SCREW COLLAR	
38	S23651001	1	固定螺钉 M6X6	SET SCREW, SOCKET (FT) M6X6	
39	SA2671001	1	切线杠杆 L	THREAD TRIMMER LEVER, L	
40	062501212	1	螺钉 M5X12	SCREW, PAN M5X12	
41	SA2826001	1	弹簧	SPRING, EXTENSION	
<hr/>					
42	SA3954001	1	旋梭基座 842TR(R)	ROTARY HOOK BASE,842TR(R)	
2	SA3961001	1	管	PIPE	
3	SA4029001	1	旋梭轴套 U	ROTARY HOOK SHAFT BUSH	
4	S09260001	1	轴向垫圈 A 1.2MM	THRUST RING, A :1.2MM< t=1.2 >	
4	SA4038001	1	轴向垫圈 1.0MM	THRUST RING< t=1.0 >	
4	S09261001	1	轴向垫圈 B 1.4MM	THRUST RING, B :1.4MM< t=1.4 >	
5	S07420000	1	滚针轴承	NEEDLE BEARING	
6	S07419001	1	峭强	RETAINING RING	
7	SA2557001	1	旋梭轴套 D	ROTARY HOOK SHAFT BUSH	
8	SA3856001	1	分线钩连杆	OPENER LINK	
9	SA3859001	1	分线钩杆	OPENER LEVER	
10	SA2560001	1	分线钩连杆轴	SHAFT, O-LINK	
11	021500316	1	六角螺母 M5	NUT, 3 M5	
12	SA3889001	1	分线钩杆短轴	O-LEVER SHAFT	
13	SA4026001	1	油线 4X4 L=100	WICK, 4X4 L=100	
14	012500536	1	螺钉 M5X5	SET SCREW, SOCKET (FT) M5X5	
15	S38212001	1	分线钩	OPENER	
16	154965001	1	螺钉 SM3. 57X8	BOLT, SOCKET SM3.57X8	

" 选购件 / OPTION PARTS "

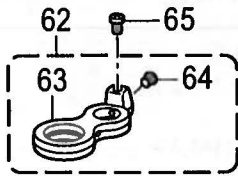

" 选购件 / OPTION PARTS "

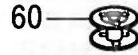
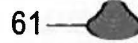

42

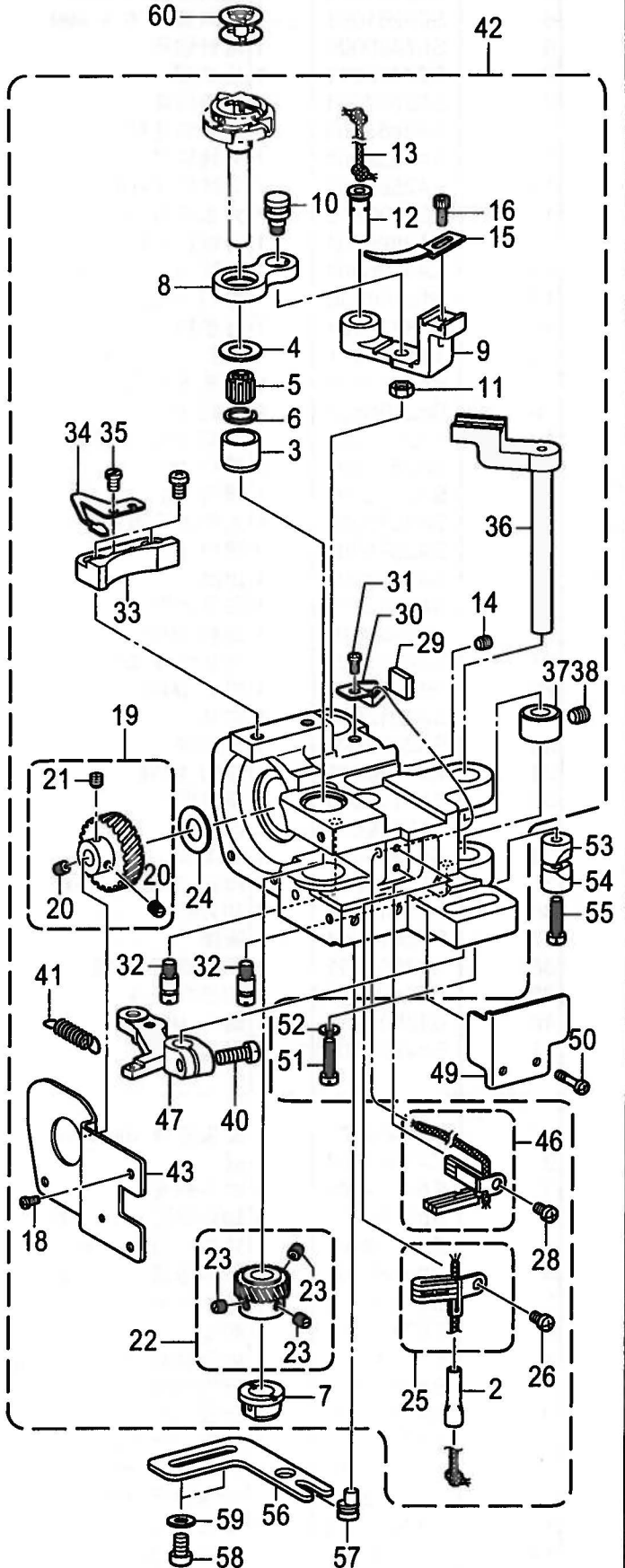
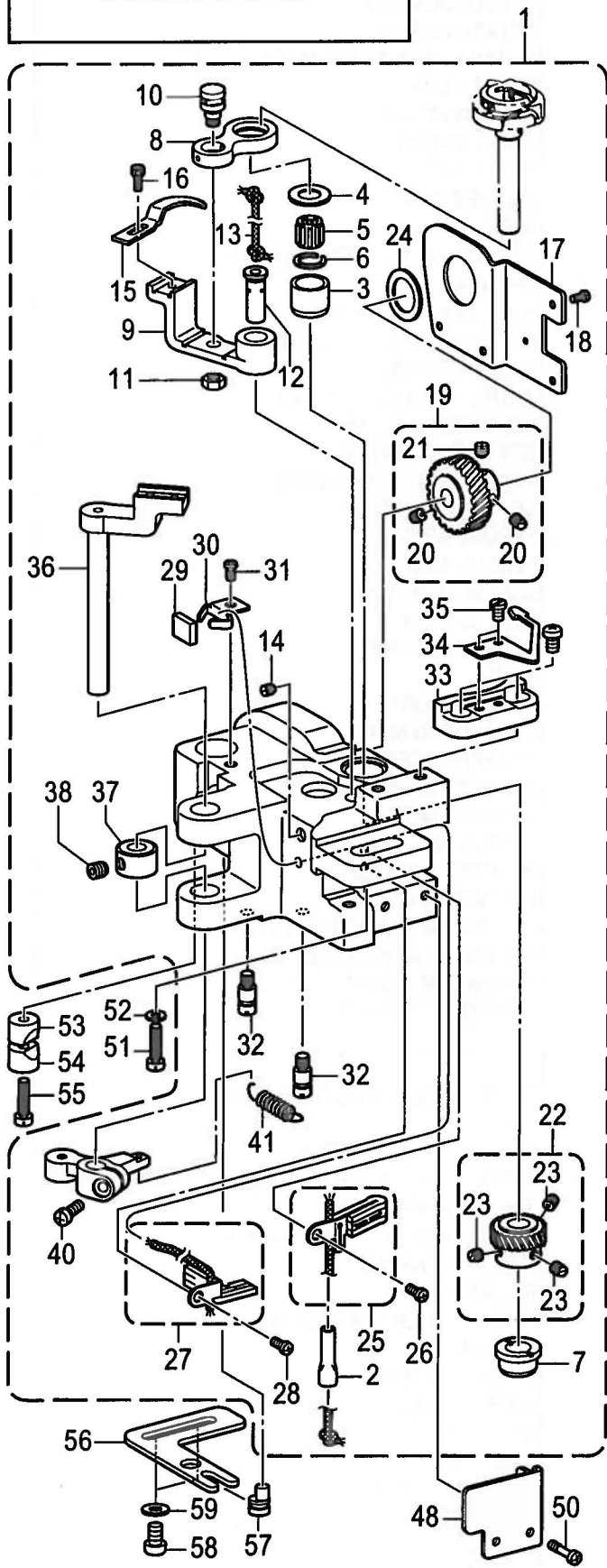

J2 . 旋梭装置(T-8422A) / Rotary hook mechanism (T-8422A)

参照号	零部件序号	数量	零部件名称	NAME OF PARTS	RM
43	SA2563101	1	旋梭底座盖 R	ROTARY HOOK BASE COVER, R	
18	062300612	4	螺钉 M3X6	SCREW, PAN M3X6	
19	SA2572001	1	螺旋齿轮 (带螺钉)	SPIRAL GEAR SCREW ASSY	
20	SA2574001	2	螺钉 M6	SET SCREW, (FT) M6	
21	SA2575001	1	螺钉 M6	SET SCREW, (FT) M6	
22	SA2576001	1	人字齿轮组件	PINION GEAR SCREW ASSY	
23	SA2575001	3	螺钉 M6	SET SCREW, (FT) M6	
44	SA2579001	1	垫圈	SPECER	
45	SA4043001	1	油毡组件 UR	FELT UR ASSY	
26	062400616	1	螺钉 M4X6	SCREW, PAN M4X6	
46	SA4045001	1	油毡组件 DR	FELT DR ASSY	
28	062400616	1	螺钉 M4X6	SCREW, PAN M4X6	
29	SA4012001	1	油毡	FELT	
30	SA3894001	1	油毡架	FELT SUPPORT	
31	062400616	1	螺钉 M4X6	SCREW, PAN M4X6	
32	SA2717001	2	定位螺钉	STOPPER SCREW	
33	SA2676001	1	动刀座	MOVABLE KNIFE BRACKET	
34	S07525000	1	板弹簧	SPRING, PLATE	
35	141544001	2	螺钉 SM3. 18-40X3	SCREW, SM3.18-40X3	
36	SA3912001	1	动刀杆	MOVABLE KNIFE LEVER	
37	SA2675001	1	紧圈	SET SCREW COLLAR	
38	S23651001	1	固定螺钉 M6X6	SET SCREW, SOCKET (FT) M6X6	
47	SA2670001	1	切线杠杆 R	THREAD TRIMMER LEVER, R	
40	062501212	1	螺钉 M5X12	SCREW, PAN M5X12	
41	SA2826001	1	弹簧	SPRING, EXTENSION	
48	SA3988001	1	旋梭底座盖 FL	ROTARY HOOK BASE COVER, FL	
49	SA3916001	1	旋梭底座盖 FR	ROTARY HOOK BASE COVER, FR	
50	SA2825001	4	螺钉 M3X12	SCREW, M3X12	
51	SA2556001	2	螺钉 M6X25	SCREW, M6X25	
52	115947001	2	垫圈 6.35	WASHER, PLAIN 6.35	
53	SA2722001	2	套管 A	PINCH SLEEVE A	
54	SA2565001	2	套管 B	PINCH SLEEVE B	
55	SA2556001	2	螺钉 M6X25	SCREW, M6X25	
56	SA2567001	2	调节板	NEEDLE UPPER POSITIONING PLATE	
57	SA2568001	2	调节轴	NEEDLE UPPER POSITIONING SHAFT	
58	062061016	4	螺钉 M6X10	SCREW, PAN M6X10	
59	025060136	4	平垫圈 S6	WASHER, PLAIN S 6	
60	S01928151	2	梭芯	BOBBIN	
61	148602001	2	“选购件” 防空转弹簧	"OPTION PARTS" ANTI-SPIN SPRING	
62	SA2827001	1	“选购件” 无油型规格 分线钩连杆组件	"OPTION PARTS" For dry type OPENER LINK ASSY	
63	SA2558001	1	分线钩连杆	OPENER LINK	
64	S58900000	1	螺钉 M2	SCREW, M2	
65	062400416	1	螺钉 M4X4	SCREW, PAN M4X4	

J3 . 旋梭装置 / Rotary hook mechanism

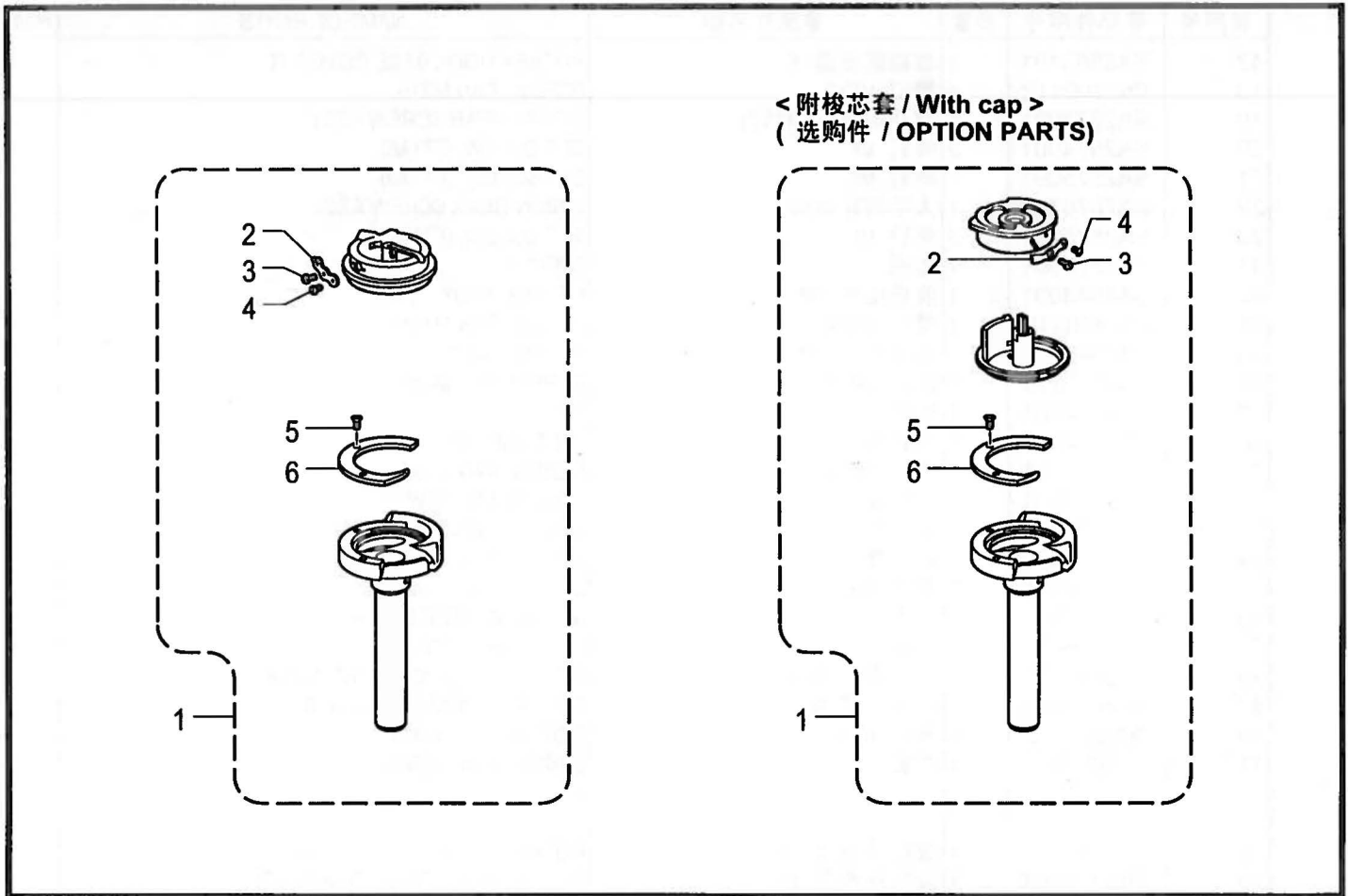

T-8421A/8422A-301

K . 定规部件 / Gauge parts

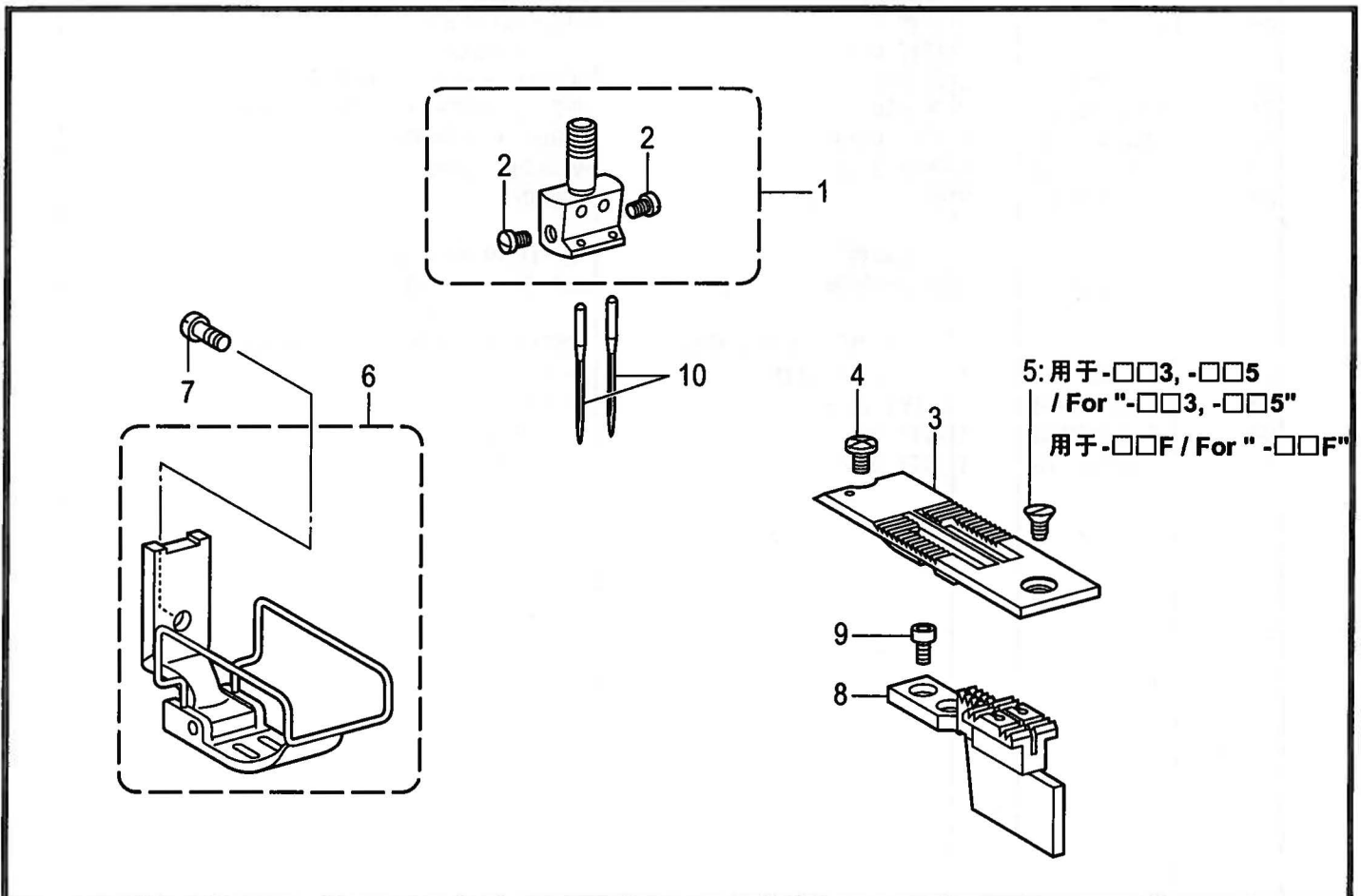

T-8421A/8422A-231

J3 . 旋梭装置 / Rotary hook mechanism

参照号	零部件序号	数量	零部件名称	NAME OF PARTS	RM
1	*	1	旋梭盒组件	ROTARY HOOK ASSY	
2	*	1	调整簧	TENSION SPRING	
3	151029-001	1	螺钉	TENSION ADJUSTING SCREW	
4	151030001	1	螺钉	SET SCREW	
5	151027001	2	螺钉	SET SCREW	
6	S07746001	1	内梭夹	INNER ROTARY HOOK HOLDER	

带 * 记号的请参考不同规格零部件一览表 (P. 54~55)。
As for symbol * look it up in the different parts list on page 54-55.

T-8421A/8422A-301

K . 定规部件 / Gauge parts

参照号	零部件序号	数量	零部件名称	NAME OF PARTS	RM
1	*	1	针夹组件	NEEDLE CLAMP ASSY	
2	116323001	2	螺钉 SM3.57	SCREW, SM3.57	
3	*	1	针板	NEEDLE PLATE	
4	S11244001	1	螺钉 SM4.37 <用于-□□3, -□□5>	SCREW, SM4.37 <For"-□□3,-□□5">	
5	100032004	1	平头螺钉 SM4.37-40X8 <用于-□□F>	SCREW, FLAT SM4.37-40X8 <For"-□□F">	
5	117160001	1	螺钉 SM4.37	SCREW, FLAT SM4.37	
6	*	1	压脚组件	PRESSER FOOT ASSY	
7	113050001	1	螺钉 SM3.57	SCREW, SM3.57	
8	*	1	送布牙	FEED DOG	
9	S07494001	2	螺钉 SM3.18X7	SCREW, W/SOCKET SM3.18X7	
10	*	2	机针 DPX5	NEEDLE, DPX5	

带 * 记号的请参考工模具一览表 (P. 56~60)。
As for symbol * look it up in the gauge parts list on page 56-60 .

T-8421A/8422A-231

L. 下轴装置 / Lower shaft mechanism

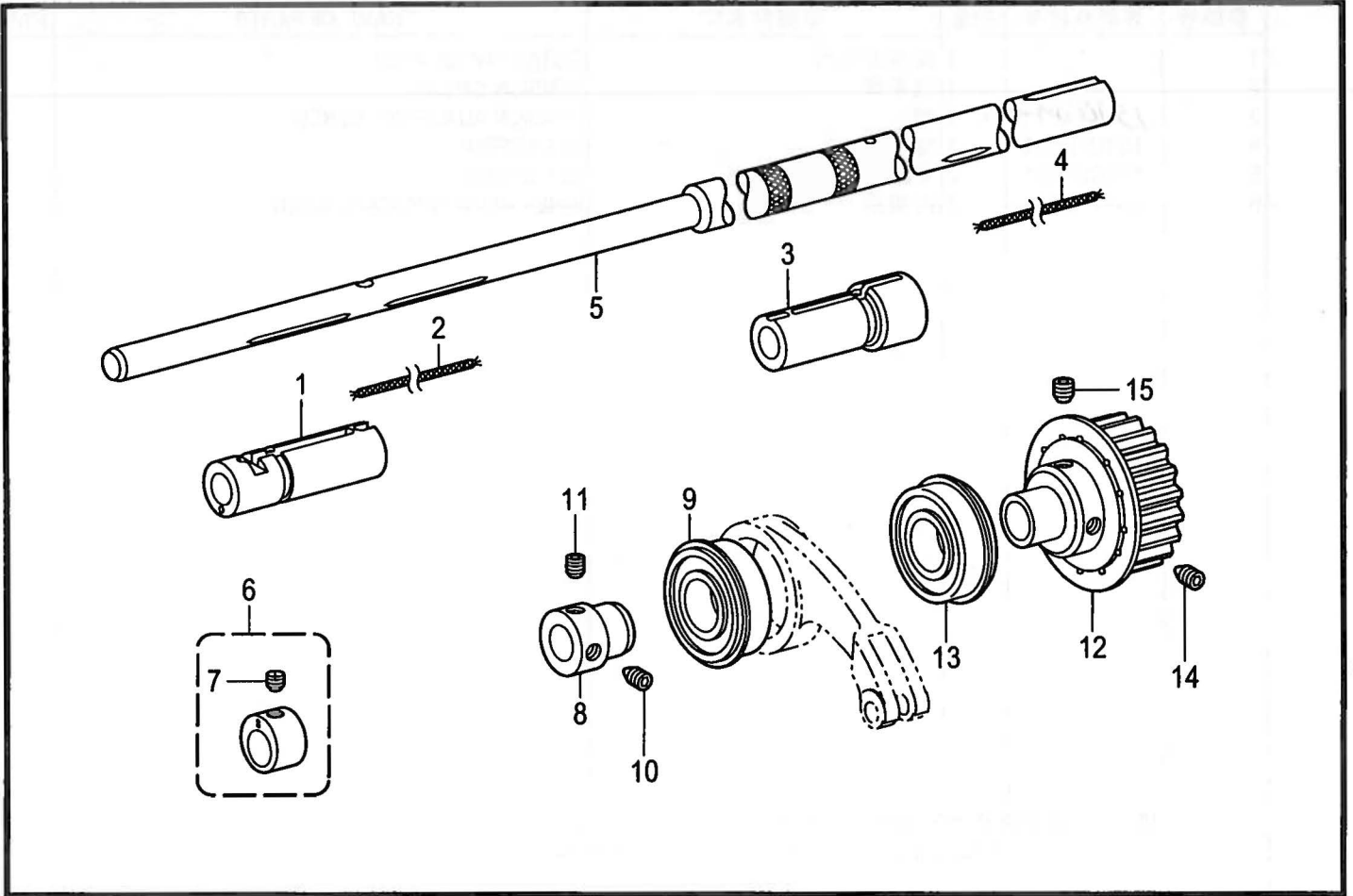

T-8421A/8422A-305

M. 松线装置 (T-8422A) / Tension release mechanism (T-8422A)

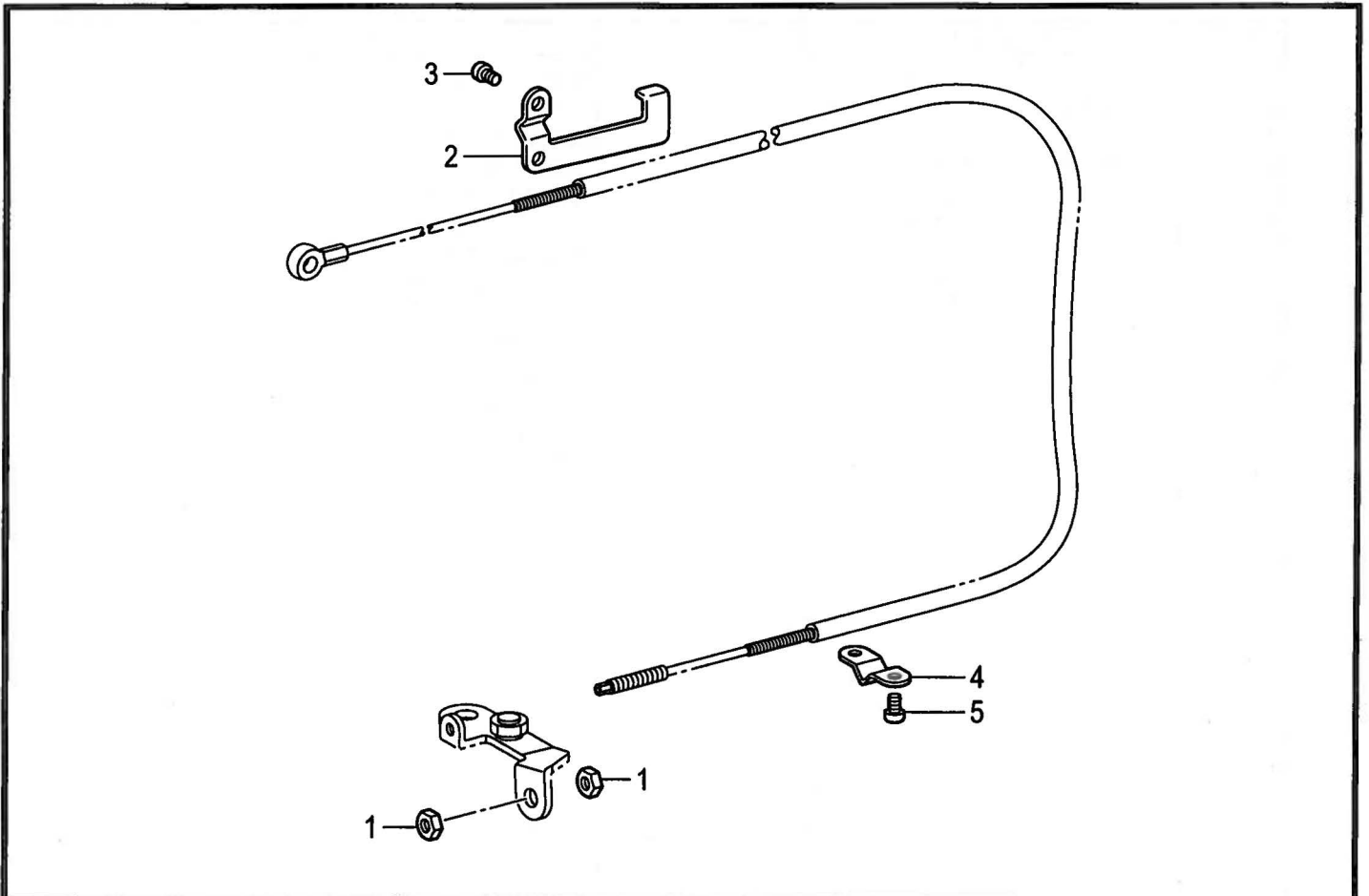

T-8422A-404

L . 下轴装置 / Lower shaft mechanism

参照号	零部件序号	数量	零部件名称	NAME OF PARTS	RM
1	SA3890001	1	旋梭基座轴套 L	ROTARY HOOK BASE BUSH, L	
2	S38481000	1	油线 L=41	WICK, L=41	
3	SA3891001	1	旋梭基座轴套 R	ROTARY HOOK BASE BUSH, R	
4	S38481000	1	油线 L=41	WICK, L=41	
5	SA2571001	1	下轴	LOWER SHAFT	
6	SA2759001	1	<T-8421A> 抬压凸轮组件	< T-8421A > F-LIFTING ECCENTRIC WHEEL ASSY	
6	SA2580001	1	< T-8422A > 抬压凸轮组件	< T-8422A > F-LIFTING ECCENTRIC WHEEL ASSY	
7	SA2575001	1	螺钉 M6	SET SCREW, (FT) M6	
8	SA2584001	1	轴承套	BALL BEARING BUSH	
9	072600480	1	球轴承 6004ZZNR	BALL BEARING, THRUST 6004ZZ	
10	SA2585001	1	固定螺钉 M6X10	SET SCREW, SOCKET (FT) M6	
11	S25236001	1	螺钉 M6X10	SET SCREW, SOCKET (FT) M6X10	
12	SA2587001	1	同步轮D组件	TIMING PULLEY ASSY, D	
13	158115001	1	球轴承 6204ZZNR	BALL BEARING, 6204ZZNR	
14	SA2585001	1	固定螺钉 M6X10	SET SCREW, SOCKET (FT) M6	
15	S25236001	1	螺钉 M6X10	SET SCREW, SOCKET (FT) M6X10	

T-8421A/8422A-305

M . 松线装置 (T-8422A) / Tension release mechanism (T-8422A)

参照号	零部件序号	数量	零部件名称	NAME OF PARTS	RM
1	110161004	2	螺母 SM4.76	NUT, SM4.76	
2	SA2678001	1	松线电线夹	TENSION RELEASE WIRE HOLDER	
3	062500816	2	螺钉 M5X8	SCREW, PAN M5X8	
4	SA2679001	1	松线电线夹	TENSION RELEASE WIRE HOLDER	
5	062060816	2	螺钉 M6X8	SCREW, PAN M6X8	

T-8422A-404

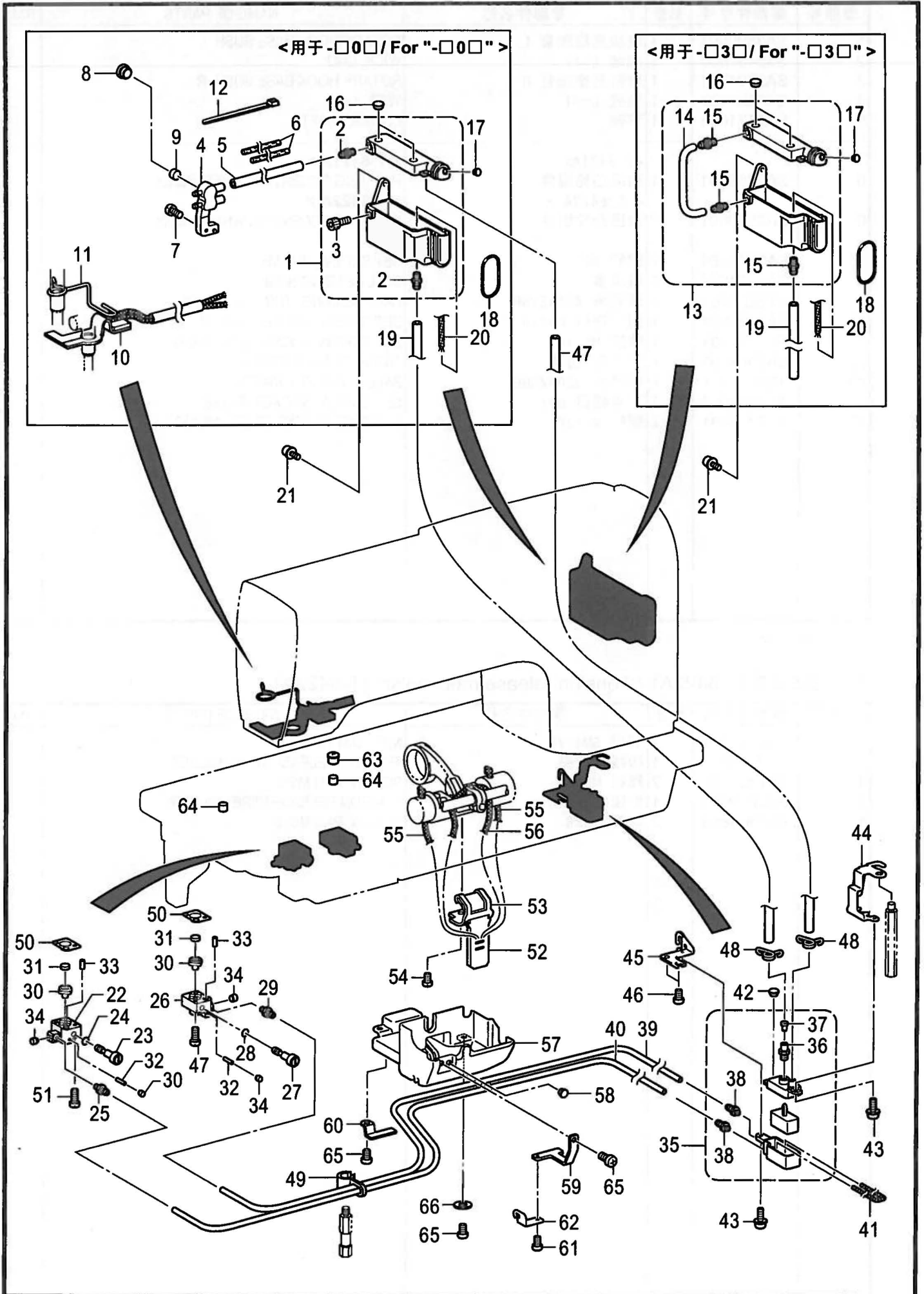

N. 供油润滑装置 / Lubrication

参照号	零部件序号	数量	零部件名称	NAME OF PARTS	RM
			<用于-□0□>	<For"-□0□">	
1	SA4205001	1	油罐组件	OIL TANK ASSY	
2	S51815001	2	供油口 8.6	OIL FEEDING PIPE, 8.6	
3	018081236	1	螺栓 M8X12	BOLT, SOCKET M8X12	
4	SA3946001	1	油管接头	OIL TERMINAL	
5	SA2956001	1	维尼龙油管 L=135	OIL TUBE, L=135	
6	SA2957001	2	油毡	FELT	
7	062500816	1	螺钉 M5X8	SCREW, PAN M5X8	
8	SA2929001	1	橡皮塞 12.5	RUBBER CAP, 12.5	
9	S38266000	1	油毡	ROTARY HOOK SHAFT FELT	
10	SA4215001	1	油毡组件	FELT ASSY	
11	SA4033001	1	油毡压架	FELT SUPPORT	
12	228475000	1	电线夹 1.9X80	FASTENING BAND 1.9X80	
			<用于-□3□>	<For"-□3□">	
13	SA2814101	1	油罐组件	OIL TANK ASSY	
14	SA3949001	1	维尼龙油管 L=50	OIL TUBE, L=50	
15	S51815001	3	供油口 8.6	OIL FEEDING PIPE, 8.6	
16	SA2929001	2	橡皮塞 12.5	RUBBER CAP, 12.5	
17	104450101	1	橡皮塞 8	RUBBER CAP, 8	
18	081038070	1	O形圈 P38	O RING P38	
19	SA2723001	1	维尼龙油管 L=210	OIL TUBE, L=210	
20	SA2724001	1	油线 L=400	WICK, L=400	
21	0A5501006	2	螺栓(带垫圈) M5X10DB	SCREW, PAN (S/P WASHE) M5X10	
22	SA3896001	1	集油器 L	OIL BLOCK,L	
23	SA2599001	1	油量调整螺栓	OIL ADJUSTING SCREW	
24	081004070	1	O形圈 P4	O RING, P4	
25	SA3147001	1	油嘴管 2.5	OIL FEEDING PIPE 2.5	
26	SA3898001	1	集油器 R	OIL BLOCK,R	
27	SA2599001	1	油量调整螺栓	OIL ADJUSTING SCREW	
28	081004070	1	O形圈 P4	O RING, P4	
29	SA3147001	1	油嘴管 2.5	OIL FEEDING PIPE 2.5	
30	SA3061001	2	橡皮垫片	RUBBER PACKING	
31	SA2727101	2	旋梭轴垫片	ROTARY HOOK SHAFT FELT	
32	S05246000	2	油毡	FELT	
33	148743001	2	油毡	FELT	
34	142274101	4	橡皮塞 4.2	RUBBER CAP, 4.2	
35	SA3037001	1	副油罐组件	SUB-TANK ASSY	
36	SA3040001	1	油嘴管	OIL FEEDING PIPE	
37	SA3060001	1	油门垫片	VALVE PACKING	
38	SA3147001	2	油嘴管 2.5	OIL FEEDING PIPE 2.5	
39	SA2597001	1	油管 L=500	OIL TUBE, L=500	
40	SA2596001	1	油管 L=400	OIL TUBE, L=400	
41	SA2598001	1	油线 L=1100	WICK, L=1100	
42	104450101	1	橡皮塞 8	RUBBER CAP, 8	
43	0A4400806	2	螺栓(带垫圈) M4X8DA	SCREW, PAN (S/P WASHER) M4X8	
44	SA3045101	1	副油罐安装架 A	SUB-TANK SETTING PLATE, A	
45	SA3046001	1	副油罐安装架 B	SUB-TANK SETTING PLATE, B	
46	062060816	2	螺钉 M6X8	SCREW, PAN M6X8	
47	SA3044001	1	维尼龙油管 L=242	OIL TUBE, L=242	
48	SA3055101	2	油管夹	TUBE CLIP	
49	SA3047001	1	油管固定夹	TUBE SUPPORT	
50	SA3923001	2	旋梭台D垫片	ROTARY HOOK BASE D PACKING	
51	062401616	4	螺钉 M4X16	SCREW, PAN M4X16	
52	SA2604001	1	油毡	FEED REGULATOR FELT	
53	SA2605001	1	油毡压架	FELT SUPPORT	
54	062500616	1	螺钉 M5X6	SCREW, PAN M5X6	
55	108802001	2	油线 4X4 L=250	WICK, 4X4 L=250	
56	108801001	1	油线 4X4 L=350	WICK, 4X4 L=350	
57	SA2606101	1	油盖	OIL COVER	
58	104450101	1	橡皮塞 8	RUBBER CAP, 8	
59	SA3048101	1	油管压架 A	TUBE SUPPORT, A	

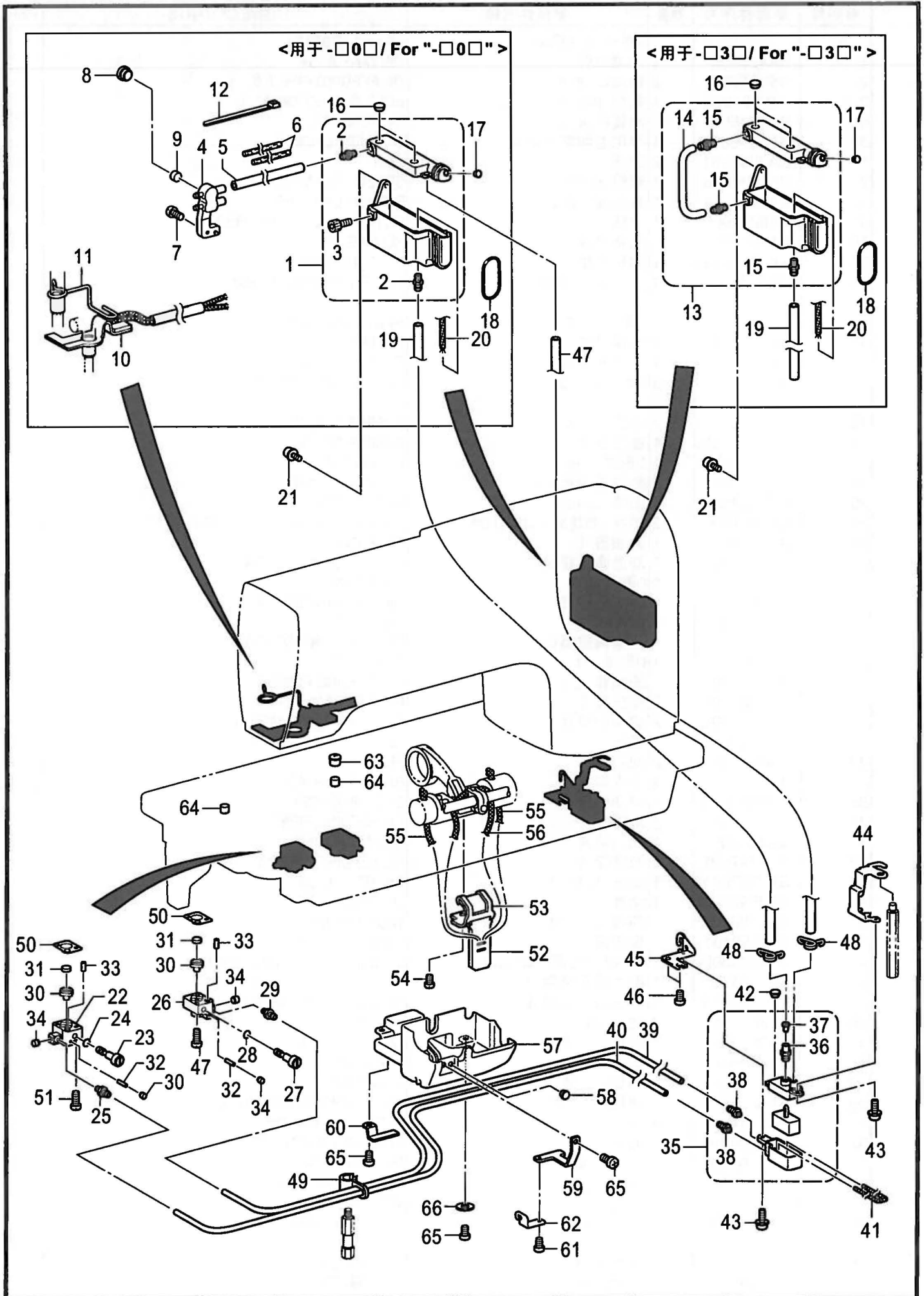

N . 供油润滑装置 / Lubrication

参照号	零部件序号	数量	零部件名称	NAME OF PARTS	RM
60	SA3049001	1	油管压架 B	TUBE SUPPORT, B	
61	062400616	1	螺钉 M4X6	SCREW, PAN M4X6	
62	SA4014001	1	油管导向	TUBE GUIDE	
63	140890009	1	油盖	OIL CAP	
64	112753001	2	油毡	FELT	
65	062061016	3	螺钉 M6X10	SCREW, PAN M6X10	
66	025060236	1	平垫圈 M6	WASHER,PLAIN M6	

P. 穿线装置 / Threading mechanism

1: 用于-□□3 / For "-□□3"
 用于-□□5 / For "-□□5"
 用于-□□F / For "-□□F"

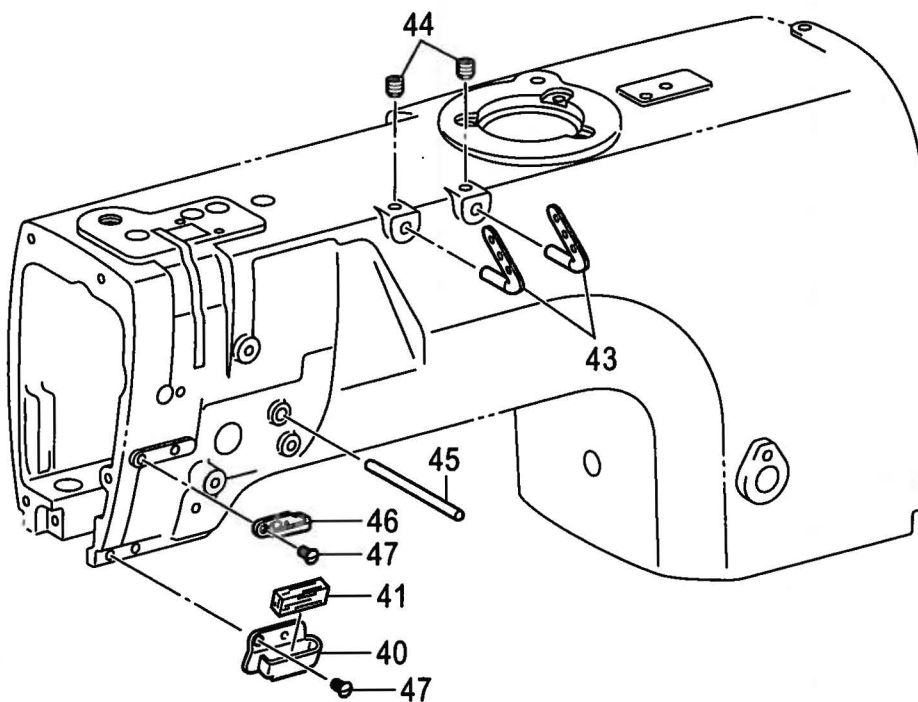
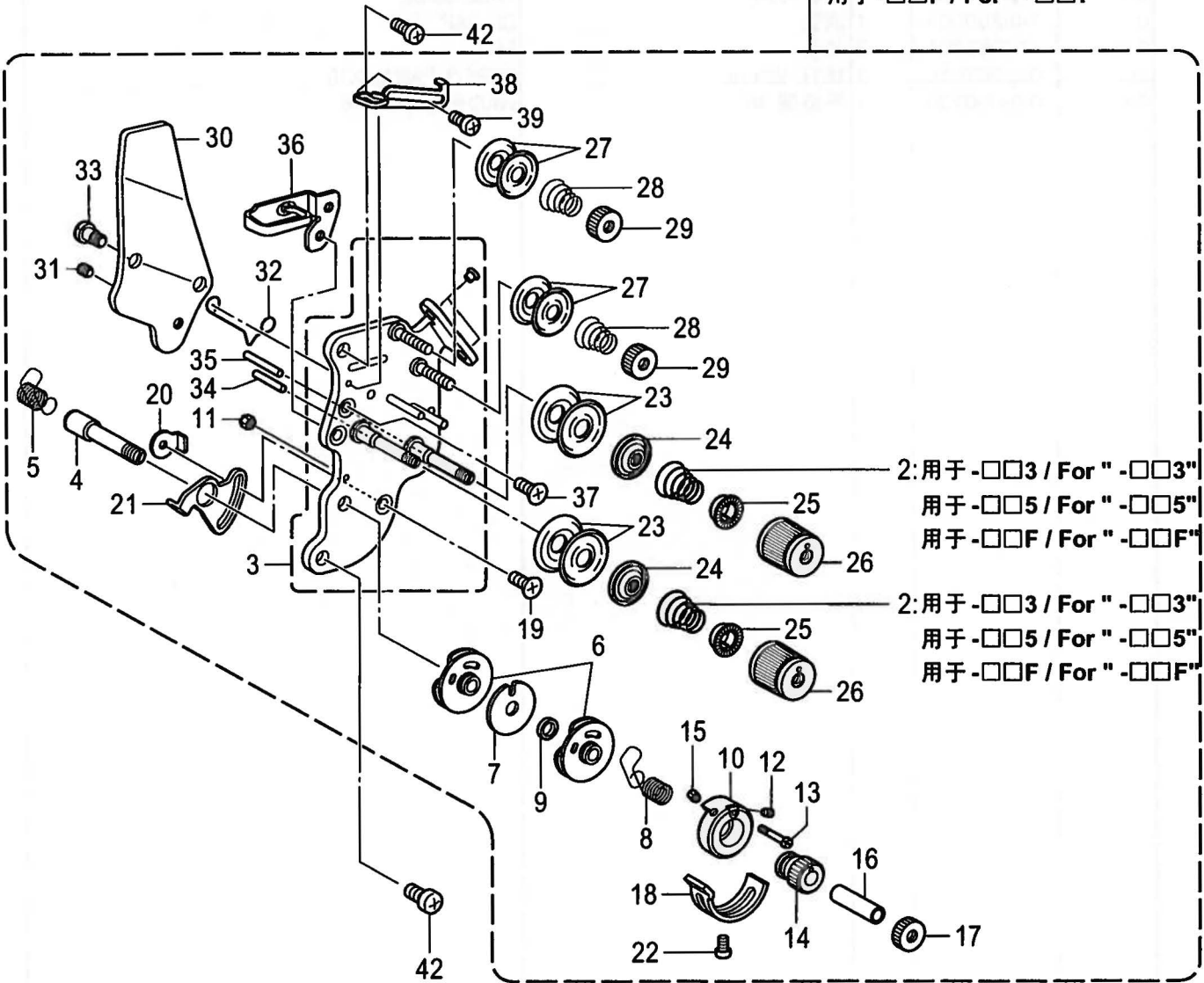

P. 穿线装置 / Threading mechanism

参照号	零部件序号	数量	零部件名称	NAME OF PARTS	RM
1	SA3417001	1	<用于-□□3> 面线调节组件 -3	<For"-□□3"> UPPER THREAD TENSION ASSY, -3	
2	SA3415001	2	弹簧 L	TENSION SPRING, L	
1	SA2607001	1	<用于-□□5> 面线调节组件 -5	<For"-□□5"> UPPER THREAD TENSION ASSY, -5	
2	SA3416001	2	弹簧 LL	TENSION SPRING, LL	
1	SA2818001	1	<用于-□□F> 面线调节组件 -1	<For"-□□F"> UPPER THREAD TENSION ASSY, -1	
2	SA3414001	2	弹簧 M	TENSION SPRING, M	
3	SA4212001	1	调整台组件	TENSION PLATE ASSY	
4	SA2613001	1	调整短轴	TENSION STUD	
5	SA2614001	1	弹簧 L	THREAD TAKE-UP SPRING, L	
6	SA2615001	2	导向组件	GUIDE ASSY, T/TAKE-UP SPRING	
7	SA2619001	1	垫片	SPACER	
8	SA2623001	1	弹簧 R	THREAD TAKE-UP SPRING, R	
9	SA2620001	1	轴套	COLLAR	
10	SA2621001	1	定位圈	STOPPER SUPPORT	
11	021300106	1	螺母 M3	NUT, 1 M3	
12	SA2626001	1	螺钉 M3.5	SET SCREW, (CP) M3.5	
13	SA2624001	1	固定螺栓	SPRING GUIDE SET SCREW	
14	SA2625001	1	调节旋钮	ADJUSTING THUMB	
15	SA2626001	1	螺钉 M3.5	SET SCREW, (CP) M3.5	
16	SA2627001	1	轴套	COLLAR	
17	SA2628001	1	调线螺母	TENSION NUT	
18	SA2629001	1	弹簧限位板	STOPPER	
19	061350616	1	螺钉 M3.5X6	SCREW, FLAT M3.5X6	
20	SA2824001	1	定位螺钉 M3.5	NUT, WHIRL-STOP M3.5	
21	SA2630001	1	限位板	STOPPER	
22	062350512	1	螺钉 M3.5X5	SCREW, PAN M3.5X5	
23	145446001	4	夹线盘	DISC, TENSION	
24	159805001	2	夹线压盘	TENSION DISC PRESSER	
25	S20681000	2	调节弹簧垫圈	WASHER	
26	S20682105	2	调节螺母	TENSION NUT	
27	144504001	4	小夹线垫片	THREAD GUIDE DISC	
28	154560001	2	小夹线弹簧 A	PRE-TENSION SPRING, A	
29	155510001	2	夹线螺母	TENSION NUT	
30	SA2632001	1	松线板	TENSION RELEASE PLATE	
31	012500536	1	螺钉 M5X5	SET SCREW, SOCKET (FT) M5X5	
32	S38274001	1	松线弹簧	T-RELEASE SPRING	
33	SA2633001	2	段螺钉 M3.5	SHOULDER SCREW, M3.5	
34	S07488001	1	松线销 L	TENSION RELEASE PIN, L	
35	158769001	1	松线销 R	TENSION RELEASE PIN, R	
36	SA2634001	1	线导向 U	THREAD GUIDE, U :ARM	
37	061350616	2	螺钉 M3.5X6	SCREW, FLAT M3.5X6	
38	SA2635001	1	线调整	THREAD QUANTITY ADJUST	
39	062300616	1	螺钉 M3X6	SCREW, PAN M3X6	
40	SA2639001	1	线导向 D	THREAD GUIDE, D :ARM	
41	114941001	1	过线钩油毡	FELT	
42	062500816	2	螺钉 M5X8	SCREW, PAN M5X8	
43	SA2636001	2	三眼线勾	THREAD RETAINER	
44	012060636	2	螺钉 M6X6	SET SCREW, SOCKET (FT) M6X6	
45	SA2637001	1	松线轴	BAR, TENSION RELEASE	
46	SA2638001	1	线导向 M	THREAD GUIDE, M :ARM	
47	SA2640001	2	螺钉 M5X8	SCREW, FLAT M5X8	

Q. 卷线装置 / Bobbin winder mechanism

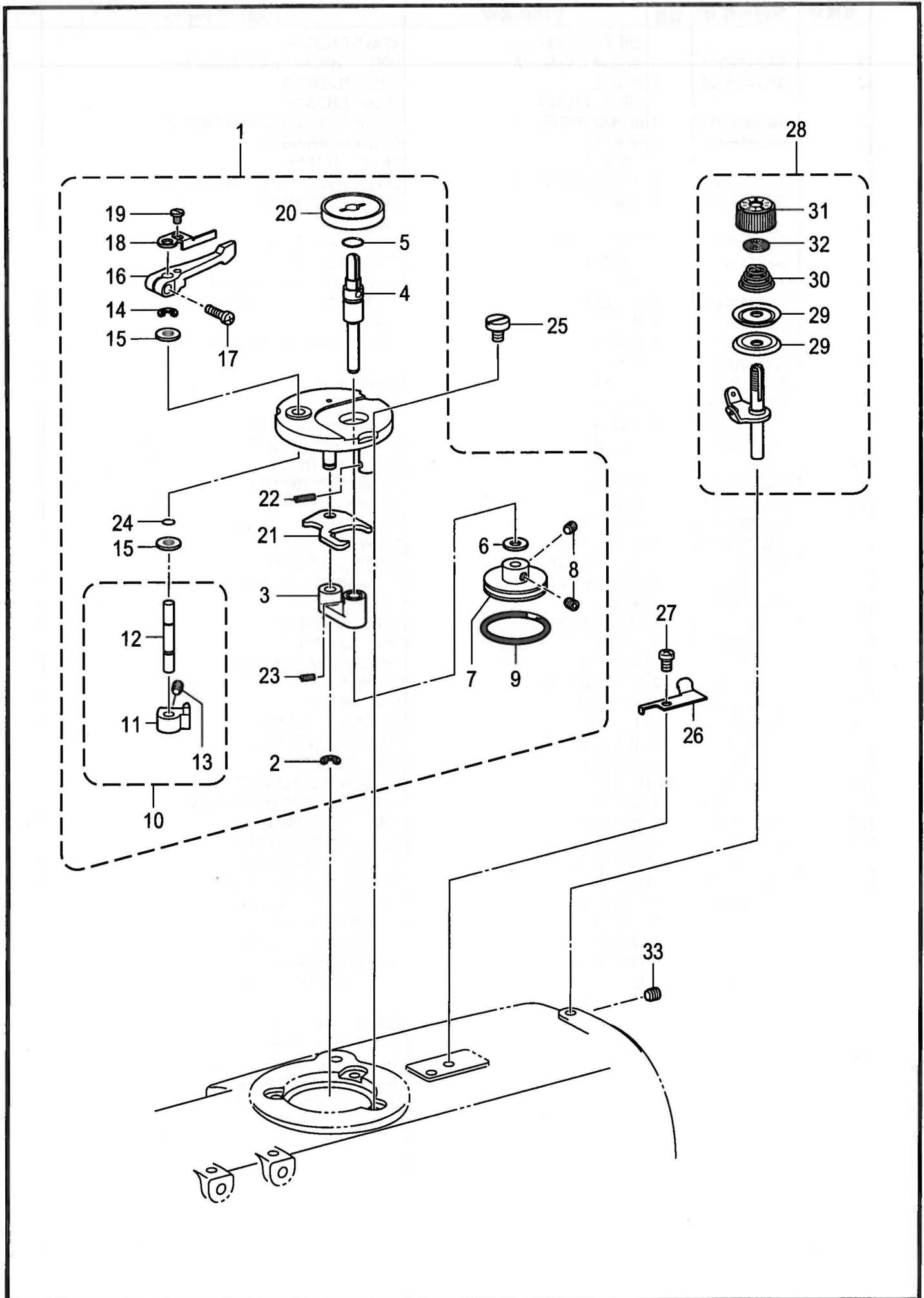

T-8421A/8422A-402

Q . 卷线装置 / Bobbin winder mechanism

参照号	零部件序号	数量	零部件名称	NAME OF PARTS	RM
1	SA1971101	1	卷线器组合件	BOBBIN WINDER UNIT	
2	048040342	1	挡圈 E4	RETAINING RING, E4	
3	SA1975001	1	卷线轴基座组件	B-WINDER SHAFT SUPPORT ASSY	
4	SA1978001	1	卷线轴	BOBBIN WINDER SHAFT	
5	081009070	1	O形圈 P9	O RING, P9	
6	025060136	1	平垫圈 S6	WASHER, PLAIN S 6	
7	SA1980001	1	卷线轮	BOBBIN WINDER WHEEL	
8	012500536	2	螺钉 M5X5	SET SCREW, SOCKET (FT) M5X5	
9	S25789000	1	橡皮垫圈 29	RUBBER RING, 29	
10	SA1981101	1	梭芯夹凸轮组件	BOBBIN PRESSER CAM ASSY	
11	SA1982101	1	梭芯夹凸轮	BOBBIN PRESSER CAM	
12	SA1983001	1	梭芯夹轴	BOBBIN WINDER ARM SHAFT	
13	012500536	1	螺钉 M5X5	SET SCREW, SOCKET (FT) M5X5	
14	048040342	1	挡圈 E4	RETAINING RING, E4	
15	025060136	2	平垫圈 S6	WASHER, PLAIN S 6	
16	SA1984001	1	梭芯压臂柄	BOBBIN PRESSER ARM	
17	062401216	1	螺钉 M4X12	SCREW, PAN M4X12	
18	SA1985001	1	梭芯夹	BOBBIN PRESSER	
19	S23418002	1	螺钉 M4X5	SCREW, M4X5	
20	SA1988001	1	梭芯座	BOBBIN SUPPORT	
21	SA1989001	1	卷线杠杆	BOBBIN WINDER LEVER	
22	SA1990101	1	弹簧	SPRING	
23	SA1991001	1	弹簧	BOBBIN WINDER BASE SPRING	
24	SA2190001	1	O形密封圈 SS5	O RING, SS5	
25	SA1992101	3	固定螺钉	BOBBIN WINDER FIXED SCREW	
26	SA1360001	1	切刀	KNIFE	
27	062500616	1	螺钉 M5X6	SCREW, PAN M5X6	
28	SA1994001	1	卷线器夹线组件	BOBBIN WINDER TENSION ASSY	
29	145446001	2	夹线盘	DISC, TENSION	
30	100401021	1	夹线弹簧	TENSION SPRING	
31	S31032001	1	压线螺母	TENSION NUT	
32	S12441001	1	止动垫圈	WASHER	
33	012500536	1	螺钉 M5X5	SET SCREW, SOCKET (FT) M5X5	

R. 切线装置 / Thread trimmer mechanism

用于 - T-8422A / For "T-8422A"

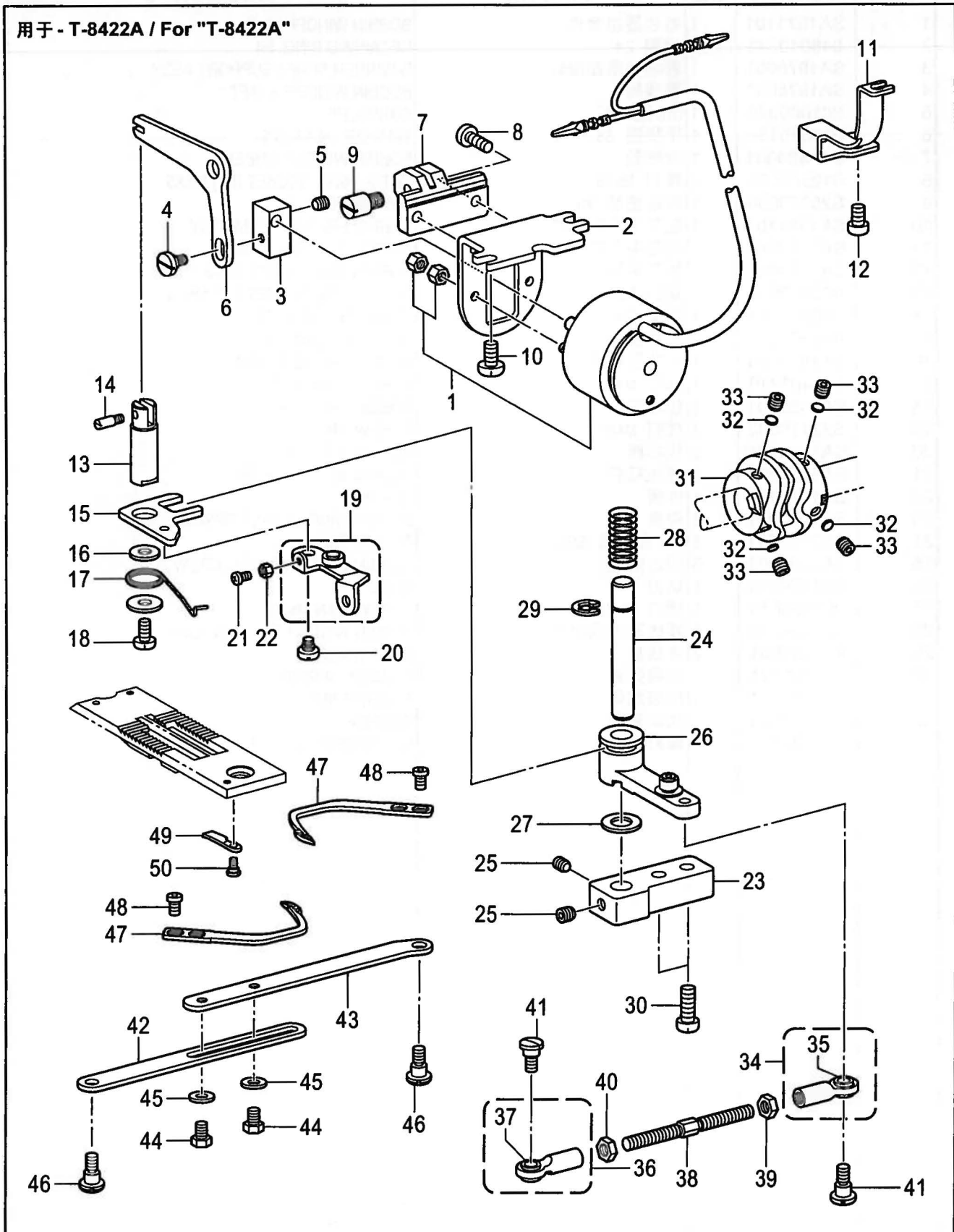

T-8422A-403

R. 切线装置 / Thread trimmer mechanism

参照号	零部件序号	数量	零部件名称	NAME OF PARTS	RM
			<用于T-8422A>	< For "T-8422A" >	
1	SA2642001	1	切线电磁铁	THREAD TRIMMER SOLENOID	
2	SA2643001	1	电磁铁架	SOLENOID BRACKET	
3	SA2644001	1	电磁铁接头	SOLENOID JOINT	
4	SA2645001	1	段螺钉 M5	SHOULDER SCREW, M5	
5	012500536	1	螺钉 M5X5	SET SCREW, SOCKET (FT) M5X5	
6	SA2646001	1	电磁铁杆	SOLENOID LEVER	
7	SA2728001	1	电磁铁杆支承架	SOLENOID LEVERB RACKET	
8	062501016	2	螺钉 M5X10	SCREW, PAN M5X10	
9	SA2647001	1	电磁铁杆短轴	SOLENOID LEVER SHAFT	
10	062061012	2	螺钉 M6X10	SCREW, PAN M6X10	
11	SA2648001	1	线夹	CORD HOLDER	
12	062060816	1	螺钉 M6X8	SCREW, PAN M6X8	
13	SA2651001	1	切线轴	DRIVING ROD	
14	148546001	1	销	PLUNGER PIN	
15	SA2652101	1	切线轴板	DRIVING ROD PLATE, TR	
16	SA2860001	1	垫圈	WASHER	
17	SA2859000	1	弹簧	SPRING, TENSION RELEASE LEVER	
18	062501016	1	螺钉 M5X10	SCREW, PAN M5X10	
19	SA2653001	1	松线杆组件	TENSION RELEASE LEVER ASSY	
20	SA2655001	1	段螺钉 M4	SHOULDER SCREW, M4	
21	062351216	1	螺钉 M3.5X12	SCREW, PAN M3.5X12	
22	021350106	1	螺母 M3.5	NUT, 1 M3.5	
23	SA2657001	1	主杆轴架	MAIN LEVER SUPPORT SHAFT	
24	SA2658001	1	主杆轴	MAIN LEVER SHAFT	
25	012060636	2	螺钉 M6X6	SET SCREW, SOCKET (FT) M6X6	
26	SA2659001	1	主杆组件	MAIN LEVER ASSY, KNIFE	
27	148559100	1	橡胶	RUBBER	
28	S07509001	1	弹簧	MAIN LEVER SPRING	
29	048070342	1	挡圈 E7	RETAINING RING, E7	
30	062061616	2	螺钉 M6X16	SCREW, PAN M6X16	
31	SA2661001	1	切线凸轮	THREAD TRIMMER CAM	
32	SA2378001	4	垫片 4.8	SPACER, 4.8	
33	S25236001	4	螺钉 M6X10	SET SCREW, SOCKET (FT) M6X10	
34	SA2663001	1	接头组件 R	ROUND JOINT ASSY, R	
35	141331002	1	管套	BUSH	
36	SA2665001	1	接头组件 L	ROUND JOINT ASSY, L	
37	141331002	1	管套	BUSH	
38	SA2667001	1	长度调节连杆	L-ADJUSTING CONNECTING ROD	
39	021060306	1	六角螺母 M6	NUT, 3 M6	
40	SA2668001	1	螺母 M6(L)	NUT, M6 LEFT	
41	SA2669001	2	段螺钉 SM5.95-28	SHOULDER SCREW, SM5.95-28	
42	SA2672001	1	切线连杆 R	T-TRIMMER CONNECTING ROD, R	
43	SA2673001	1	切线连杆 L	T-TRIMMER CONNECTING ROD, L	
44	017500812	2	六角螺栓 M5X8	BOLT, M5X8	
45	025050236	2	平垫圈 M5	WASHER, PLAIN M 5	
46	SA2645001	2	段螺钉 M5	SHOULDER SCREW, M5	
47	S07526201	2	动刀	MOVABLE KNIFE	
48	148536001	4	螺钉 SM4.37-40X4.2	SCREW, W/SOCKET SM4.37-40X4.2	
49	S07527001	2	定刀	FIXED KNIFE	
50	148539101	2	段螺钉 SM2.38	SHOULDER SCREW, SM2.38	
			<用于T-8421A / 8422A>	< For "T-8421A / 8422A" >	
51	S38687000	1	插头 5557-14R	CONNECTOR, 5557-14R	
52	SA1998001	1	接地线组件	GROUND WIRE ASSY	
53	062500816	1	螺钉 M5X8	SCREW, PAN M5X8	
54	340400001	2	线夹	BEAD BAND	

S. 扫线装置(T-8422A) / Thread wiper mechanism (T-8422A)

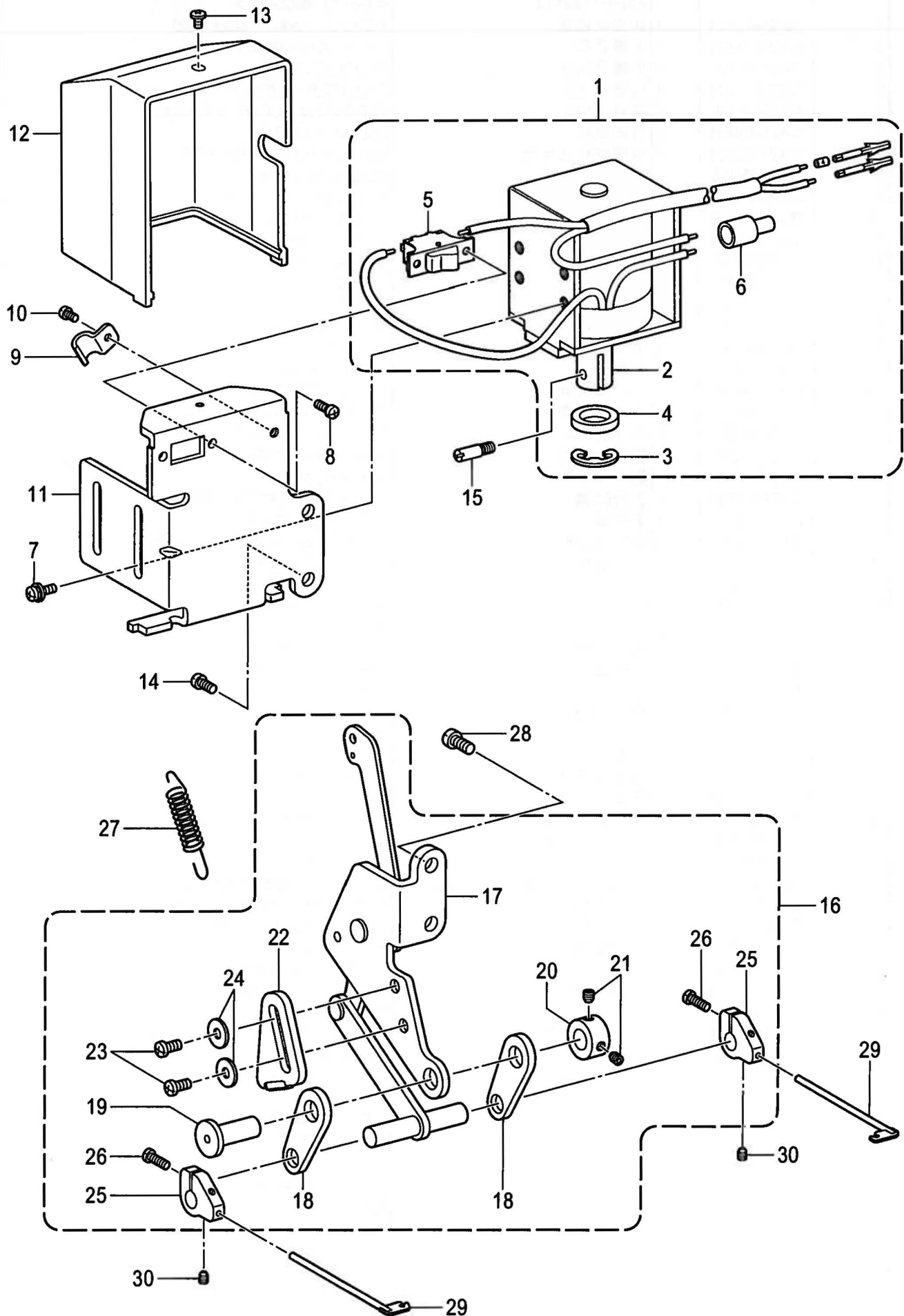

T-8422A-405

S. 扫线装置(T-8422A) / Thread wiper mechanism (T-8422A)

参照号	零部件序号	数量	零部件名称	NAME OF PARTS	RM
1	SA2680001	1	扫线电磁铁组件	THREAD WIPER SOLENOID ASSY	
2	148511001	1	插棒式铁芯	PLUNGER	
3	048090342	1	挡圈 E9	RETAINING RING, E9	
4	S38426000	1	橡皮垫	PLUNGER RUBBER	
5	S02664001	1	挡线开关	THREAD WIPER SWITCH	
6	S02665000	1	电线接头	TERMINAL CONNECTOR	
7	S39048001	4	螺钉(带垫片) M4X10	SCREW, PAN (S/P W) M4X10	
8	062300616	2	螺钉 M3X6	SCREW, PAN M3X6	
9	140647101	1	电线固定夹	CORD HOLDER	
10	062400616	1	螺钉 M4X6	SCREW, PAN M4X6	
11	SA2732001	1	电磁铁安装板	SOLENOID HOLDING PLATE	
12	SA2696001	1	电磁铁盖	SOLENOID COVER	
13	060400516	1	螺钉 M4X5	SCREW, BIND M4X5	
14	062501016	2	螺钉 M5X10	SCREW, PAN M5X10	
15	148546001	1	销	PLUNGER PIN	
16	SA2682001	1	电磁铁连杆组件	THREAD WIPER SOLENOID ASSY	
17	SA2683001	1	电磁铁连杆	SOLENOID LINK	
18	S07549101	2	连接板 C	THREAD WIPER LINK, C	
19	S07550001	1	连接板轴	LINK STUD	
20	SA2504001	1	紧圈	SET SCREW COLLAR	
21	012500536	2	螺钉 M5X5	SET SCREW, SOCKET (FT) M5X5	
22	S38421001	1	定位板	STOPPER	
23	062500816	2	螺钉 M5X8	SCREW, PAN M5X8	
24	025050236	2	平垫圈 M5	WASHER, PLAIN M 5	
25	S07552001	2	扫线器架	THREAD WIPER SUPPORT	
26	062661212	2	螺钉 SM3.18-40X12	SCREW, PAN SM3.18-40X12	
27	SA2684001	1	弹簧	THREAD WIPER SPRING	
28	062501016	2	螺钉 M5X10	SCREW, PAN M5X10	
29	S07553001	2	扫线器	THREAD WIPER	
30	S07424001	2	螺钉 SM3.18X4	SET SCREW, W/SOCKET SM3.18X4	

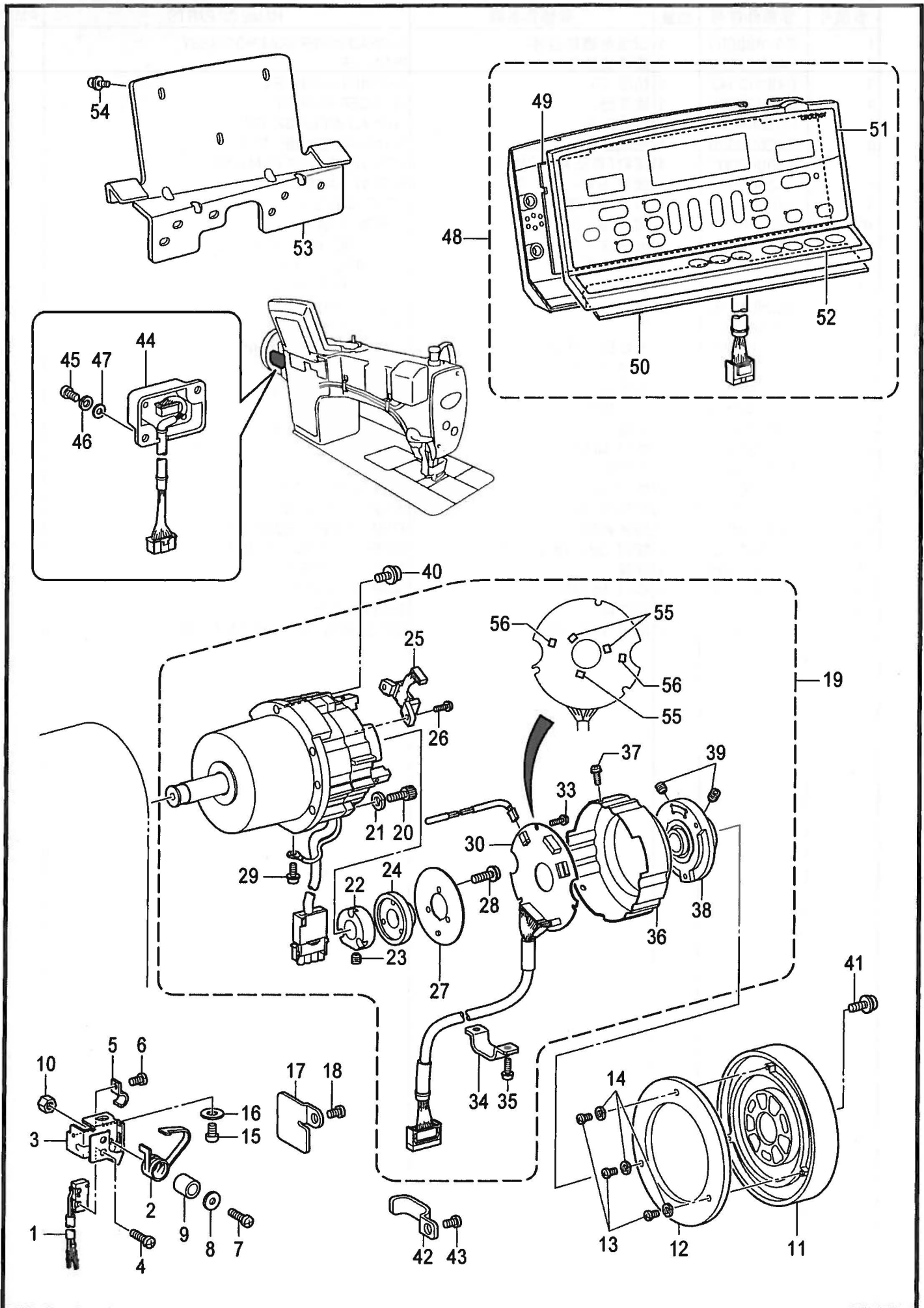

T1 . 控制箱 · 马达装置 / Control box & motor mechanism

参照号	零部件序号	数量	零部件名称	NAME OF PARTS	RM
1	SA1385001	1	微处理开关组件	MICRO SWITCH ASSY	
2	S38744101	1	板弹簧	SWITCH PLATE SPRING	
3	SA2686001	1	开关基座	SWITCH BASE	
4	062020806	2	螺钉 M2X8	SCREW, PAN M2X8	
5	140647101	1	电线固定夹	CORD HOLDER	
6	062400616	1	螺钉 M4X6	SCREW, PAN M4X6	
7	062401216	1	螺钉 M4X12	SCREW, PAN M4X12	
8	026040236	1	平垫圈 4	WASHER, PLAIN M 4	
9	154514001	1	衬垫	SPACER	
10	021400106	1	六角螺母 M4	NUT, 1 M4	
11	SA4040001	1	手轮 CDD	PULLEY,CDD	
12	SA3175001	1	导向板	GUARD PLATE	
13	062300616	3	螺钉 M3X6	SCREW, PAN M3X6	
14	028030246	3	弹簧垫圈 2-3	WASHER, SPRING 2-3	
15	062060812	1	螺钉 M6X8	SCREW, PAN M6X8	
16	025060136	1	平垫圈 S6	WASHER, PLAIN S 6	
17	SA2712001	1	电线固定夹	CORD HOLDER	
18	062500816	1	螺钉 M5X8	SCREW, PAN M5X8	
19	J80990001	1	马达组件 CDD-HT	MOTOR ASSY, CDD-HT	
20	018501632	3	螺栓 M5X16	BOLT, SOCKET M5X16	
21	028050242	3	弹簧垫圈 2-5	WASHER, SPRING 2-5	
22	J03955001	1	磁鼓 CDD	DRUM CDD	
23	014400632	2	螺钉 M4X6	SET SCREW, SOCKET (CP) M4X6	
24	J03956001	1	磁铁 180P36	MAGNET 180P36	
25	J03957001	1	MR感应器组件 180P	MR SENSOR ASSY 180P	
26	0A4300805	2	螺栓(带垫圈) M3X8DA	SCREW, PAN (S/P WASHER) M3X8	
27	J03958001	1	屏蔽板 CDD	SHIELD PLATE CDD	
28	0A4261005	3	螺栓(带垫圈) M2.6X10DA	SCREW, PAN (S/P WASHE) M2.6X10	
29	0A4401005	1	螺栓(带垫圈) M4X10DA	SCREW, PAN (S/P WASHE) M4X10	
30	J80971001	1	CDD-ENC基板组件	PCB ASSY, CDD-ENC	
33	0A5300606	3	螺栓(带垫圈) M3X6DB	SCREW, PAN (S/P WASHER) M3X6	
34	J04230001	1	电线固定夹 CDD-HT	CORD HOLDER, CDD-HT	
35	0A4401005	2	螺栓(带垫圈) M4X10DA	SCREW, PAN (S/P WASHE) M4X10	
36	J04296001	1	编码器盖 CDD#2	ENCODER COVER, CDD #2	
37	0A4300805	3	螺栓(带垫圈) M3X8DA	SCREW, PAN (S/P WASHER) M3X8	
38	J03964001	1	马达轮安装基座组件 CDD	PULLEY HOLDER ASSY CDD	
39	014500632	2	螺钉 M5X6	SET SCREW, SOCKET (CP) M5X6	
40	SA2354001	5	螺钉 M5X18	SCREW, PAN M5X18	
41	SA3025001	3	螺栓(带垫圈) M4X10DA	SCREW,PAN(S/P WASHER)M4X10	
42	SA2687001	1	电线固定夹	CORD HOLDER	
43	062500816	1	螺钉 M5X8	SCREW, PAN M5X8	
44	SA4194001	1	头部传感元件	HEAD DETECTOR UNIT	
45	062500816	2	螺钉 M5X8	SCREW, PAN M5X8	
46	028050246	2	弹簧垫圈 2-5	WASHER, SPRING 2-5	
47	026050136	2	平垫圈 S5	WASHER, PLAIN S 5	
48	J80969001	1	操作盘组件	PANEL ASSY	
49	J80973001	1	G40操作盘基板组件	G40 PANEL PCB ASSY	
50	J80974001	1	G40副基板组件	G40 SUB PCB ASSY	
51	J03975001	1	G40操作盘面板 1	G40 PANEL SEAT 1	
52	J03976001	1	G40操作盘面板 2	G40 PANEL SEAT 2	
53	J04195001	1	操作盘安装架 #2	PANEL SETTING PLATE#2	
54	J04273001	3	螺栓(带垫圈) M4X10DB	SCREW, PAN(S/P WASHER)M4X10	
55	J03983001	3	霍尔元件 ICE W-400	HALL ELEMENT:ICE-400	
56	J03984001	2	霍尔元件 ICE W-450	HALL ELEMENT:ICE-450	

< 用于 AC380-415V / For "380-415V AC" >

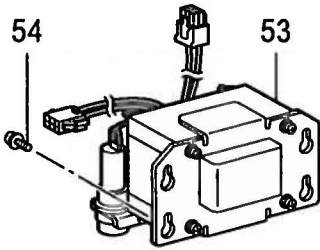

48: 用于 AC100-110V / For "100-110V AC"
49: 用于 AC200-230V / For "200-230V AC"

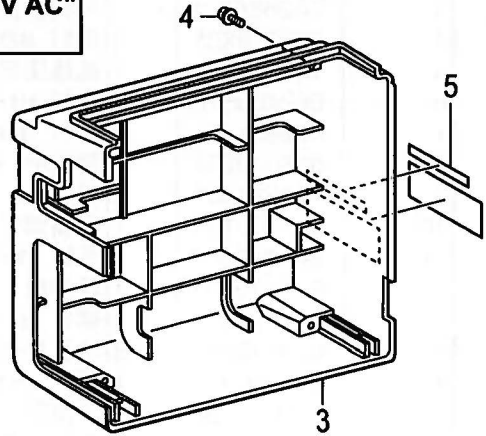
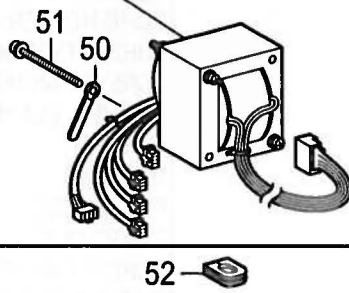

< 用于欧洲 / For Europe >

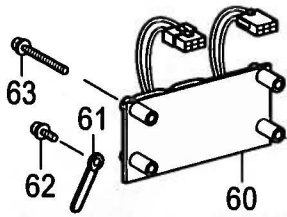

64

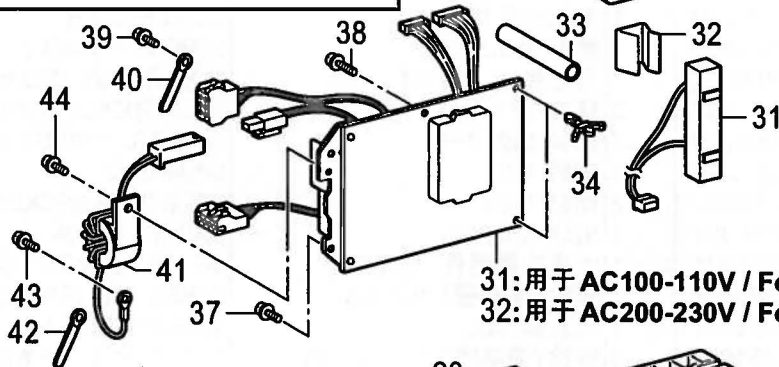

31: 用于 AC100-110V / For "100-110V AC"
32: 用于 AC200-230V / For "200-230V AC"

< 用于 AC380-415V / For "380-415V AC" >

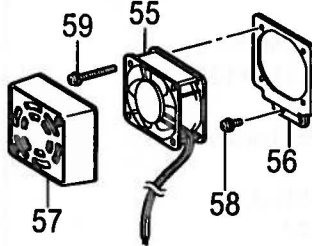

< 用于美国、欧洲 / For U.S.A., Europe >

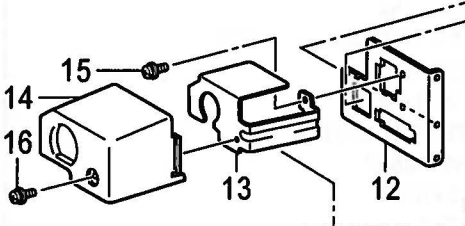

< 用于美国 / For U.S.A. >

67

< 用于欧洲 / For Europe >

65, 66

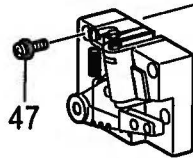

45: 前·后各一档规格 / Type forward 1 step, backward 1 step >

46: 前·后各二档规格 / Type forward 2 step, backward 2 step >

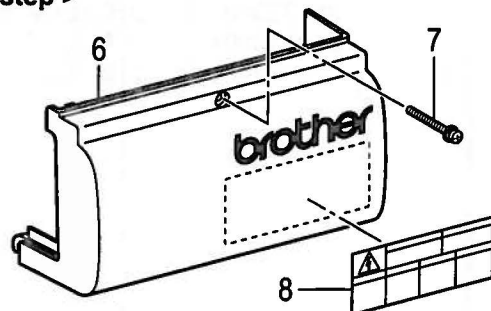
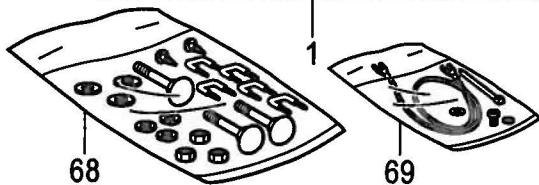
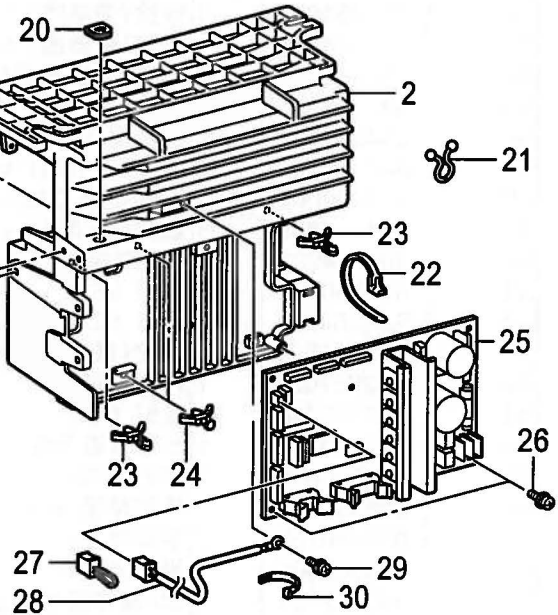

T2 . 控制箱装置 / Control box mechanism

参照号	零部件序号	数量	零部件名称	NAME OF PARTS	RM
1	J80976101	1	<用于日本 单相100V > 控制箱组件 CDD1100A-1	< For Japan, Single phase 100V AC > BOX ASSY, CDD1100A-1	
1	J80977101	1	<用于美国 单相110V> 控制箱组件 CDD1110A-L	<For USA, Single phase 110V AC > BOX ASSY, CDD1110A-L	
1	J80979101	1	<用于一般亚洲 单相220V> 控制箱组件 CDD1230A-1	<For General of Asia, Single phase 220V AC > BOX ASSY, CDD1230A-1	
1	J80980101	1	<用于中国 单相220V> 控制箱组件 CDD1230A-2	<For China, Single phase 220V AC > BOX ASSY, CDD1230A-2	
1	J80981001	1	<用于土耳其, 北非洲 单相220V> 控制箱组件 CDD1230A-3	<For Turkey & North africa, Single phase 220V AC > BOX ASSY, CDD1230A-3	
1	J80982101	1	<用于欧洲 单相230V> 控制箱组件 CDD1230ACE	<For Europe, Single phase 230V AC > BOX ASSY, CDD1230ACE	
1	J80984101	1	<用于日本 三相200V> 控制箱组件 CDD3200A-1	<For Japan, Three phase 200V AC > BOX ASSY, CDD3200A-1	
1	J80985101	1	<用于美国 三相220V> 控制箱组件 CDD3230A-L	<For USA, Three phase 220V AC > BOX ASSY, CDD3230A-L	
1	J80987101	1	<用于一般亚洲 三相380V> 控制箱组件 CDD1400A-1	<For General of Asia, Three phase 380V AC > BOX ASSY, CDD1400A-1	
1	J80988101	1	<用于中国 三相380V> 控制箱组件 CDD1400A-2	<For China, Three phase 380V AC > BOX ASSY, CDD1400A-2	
1	J80989101	1	<用于土耳其, 北非洲 三相380V> 控制箱组件 CDD1400A-3	<For Turkey & North africa, Three phase 380V AC > BOX ASSY, CDD1400A-3	
2	J03929001	1	CDD框架	BASE FRAME, CDD	
3	J03930001	1	CDD后箱盖	REAR BOX COVER, CDD	
4	229017001	4	螺栓(带垫圈) M4X10DA	SCREW, PAN (S/P WASHER) M4X10	
5	J04136001	1	标牌 3P380-415V	LABEL, 3P380-415V	
6	J03931001	1	CDD前箱盖	FRONT BOX COVER, CDD	
7	J02568001	1	螺栓(带垫圈) M4X25DA	SCREW, PAN (S/P WASHER) M4X25	
8	J04115001	1	感电标签(6国)	LABEL, ELEC. SHOCK 6 LANG.	
9	J03934001	1	插孔板 1	CONNECTOR PLATE1	
10	229017001	1	螺栓(带垫圈)M4X10DA	SCREW, PAN (S/P WASHER) M4X10	
11	J02039002	1	盖-INV	FOOT PLUG CAP, INV	
12	J04140001	1	插孔板 1-2	CONNECTOR PLATE1-2	
13	J03935001	1	插孔板 2	CONNECTOR PLATE2	
14	J04137001	1	电线盖 CDD	POWER CODE COVER, CDD	
15	229017001	1	螺栓(带垫圈) M4X10DA	SCREW, PAN (S/P WASHER) M4X10	
16	229017001	1	螺栓(带垫圈) M4X10DA	SCREW, PAN (S/P WASHER) M4X10	
17	062400863	1	螺钉 M4X8	SCREW, PAN M4X8	
18	028040245	1	弹簧垫圈 2-4	WASHER, SPRING 2-4	
19	025040173	1	平垫圈 S4	WASHER, PLAIN S 4	
20	J00953001	1	电线压夹 #DD2	CORD BUSHING, #DD2	
21	J04164001	2	Ω形夹子 OLS-80	CLAMP, OLS-80	
22	J02825001	1	电线固定夹 RF140	REPEAT CABLE TIE, RF140	
23	228295001	2	碟柄 KGLS-6S	HOLDER, KGLS-6S	
24	J01892001	2	接头 KGPS-6S	HOLDER, KGPS-6S	
25	J80964101	1	S基板组件 CDD#2	CONTROL PCB ASSY, CDD#3	
26	229017001	2	螺栓(带垫圈)M4X10DA <用于AC400V以外>	SCREW, PAN (S/P WASHER) M4X10 <For Others "400V AC">	
27	J04168001	1	短路插座 <用于AC400V用>	SHORT CONNECTOR <For "400V AC">	
28	J04169001	1	CDD热控管 #2	THERMISTOR, CDD #2	

T2. 控制箱装置 / Control box mechanism

参照号	零部件序号	数量	零部件名称	NAME OF PARTS	RM
29	0A4300805	1	螺栓(带垫圈) M3X8DA	SCREW, PAN (S/P WASHER) M3X8	
30	220681001	1	电线夹 2.2X85	CABLE TIE	
31	J80965001	1	<用于AC110V> D基板组件 CDD1-110V	<For "110V AC"> POWER PCB ASSY, CDD 1-110V	
32	J80966001	1	<用于AC220-240V> D基板组件 CDD3-230V	<For "220 - 240V AC"> POWER PCB ASSY, CDD 3-230V	
33	J04100001	1	电阻组件 R40/220#6	CEMENT RESISTOR ASSY, 40/220#6	
34	J03739001	1	CR固定夹	SPRING PLATE, CR	
35	J04155001	1	管 9/16X80	TUBE, 9/16X80	
36	228295001	2	碟柄 KGLS-6S	HOLDER, KGLS-6S	
37	229017001	2	螺栓(带垫圈) M4X10DA	SCREW, PAN (S/P WASHER) M4X10	
38	J00494001	2	螺栓(带垫圈) M4X14DA	SCREW, PAN (S/P WASHER) M4X14	
39	229017001	1	螺栓(带垫圈) M4X10DA	SCREW, PAN (S/P WASHER) M4X10	
40	414959001	1	固定用线夹	WIRE CLIP	
41	J02725001	1	地磁感应器 #2	EARTH INDUCTOR	
42	414959001	1	固定用线夹	WIRE CLIP	
43	229017001	1	螺栓(带垫圈) M4X10DA	SCREW, PAN (S/P WASHER) M4X10	
44	229017001	1	螺栓(带垫圈) M4X10DA	SCREW, PAN (S/P WASHER) M4X10	
45	J80967001	1	<前·后各一档规格> 踏脚控制器CDD(日本国内)	<Type forward 1 step, backward 1 step> TREADLE UNIT ASSY, CDD G	
46	J80968001	1	<前·后各二档规格> 踏脚控制器CDD(出口用)	<Type forward 2 step, backward 2 step> TREADLE UNIT ASSY, CDD H	
47	J00353001	3	螺栓(带垫圈) M5X14DB	SCREW, PAN (S/P WASHER) M5X14	
48	J04097001	1	<用于AC100-110V> 变压器 CDD-100V	<For "100 - 110V AC"> TRANSFORMER, CDD-100V	
49	J04098001	1	<用于AC200-230V> 变压器 CDD-200V	<For "200 - 230V AC"> TRANSFORMER, CDD-200V	
50	414959001	1	<用于AC100-200V 变压器> 固定用线夹	<For Transformer of "100 - 200V AC"> WIRE CLIP	
51	J01411001	2	螺栓(带垫圈) M4X50DA	SCREW, PAN (S/P WASHER) M4X50	
52	J03936001	1	电线压夹	CODE BUSHING	
53	J03939001	1	<用于AC380-415V> 变压器 400V	<For "380 - 415V AC"> TRANSFORMER, 400V	
54	229017001	5	<用于AC400V 变压器> 螺栓(带垫圈) M4X10DA	<For Transformer of "400V AC"> SCREW, PAN (S/P WASHER) M4X10	
55	J04167001	1	<用于AC380-415V> DC风扇CDD组件 #2	<For "380 - 415V AC"> DC FAN ASSY, CDD #2	
56	J04147001	1	风扇安装板	FAN SETTING PLATE, CDD	
57	J04148001	1	风扇盖	FAN COVER, CDD	
58	229017001	2	螺栓(带垫圈) M4X10DA	SCREW, PAN (S/P WASHER) M4X10	
59	0A4403505	4	螺栓(带垫圈) M4X35DA	SCREW, PAN (S/P WASHER) M4X35	
60	J80970001	1	<用于欧洲> CE过滤基板组件	<For Europe> CE FILTER PCB ASSY	
61	414959001	1	<用于欧洲 AC400V> 固定用线夹	<For Europe, "400V AC"> WIRE CLIP	
62	229017001	1	螺栓(带垫圈) M4X10DA	SCREW, PAN (S/P WASHER) M4X10	
63	0A4402506	4	<用于欧洲的过滤基板> 螺栓(带垫圈) M4X25DA	<For Filter PCB of Europe> SCREW, PAN (S/P WASHER) M4X25	
64	UK3745000	2	<用于欧洲> 铁芯 SD-SR-12	<For Europe> CORE:SD-SR-12	

T-8421A/8422A-502

T2 . 控制箱装置 / Control box mechanism

参照号	零部件序号	数量	零部件名称	NAME OF PARTS	RM
65	414959001	1	<用于欧洲 AC400V> 固定用线夹	<For Europe, "400V AC"> WIRE CLIP	
66	229017001	1	螺栓(带垫圈) M4X10DA	SCREW, PAN (S/P WASHER) M4X10	
67	J02195001	1	<用于美国> 压夹 SR-7K-2	<For USA> BUSHING, :SR-7K-2	
68	J04210001	1	螺钉一组 M8X65	BOLT ASSY, SQUARE M8X65	
69	J04243001	1	地线螺钉组件	EARTH CORD SCREW TIE ASSY	
70	J04099001	1	插头组件 CDD	FOOT PLUG ASSY, CDD	

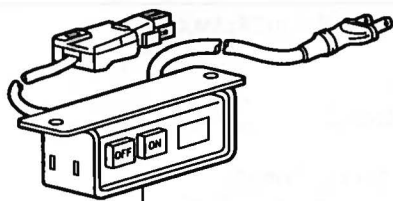

1: 用于日本单相 100V
/ For Japan 1-phase 100V AC

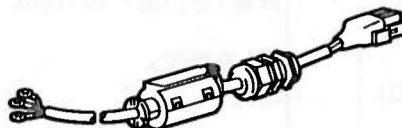

5: 用于欧洲单相 220V-240V
/ For Europe 1-phase 220V-240V AC

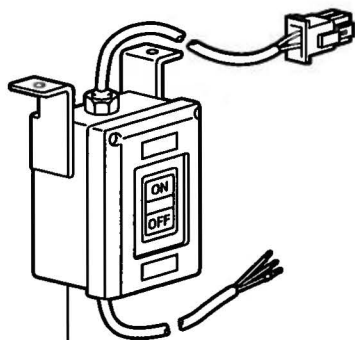

2: 单相 110V
/ 1-phase 110V AC

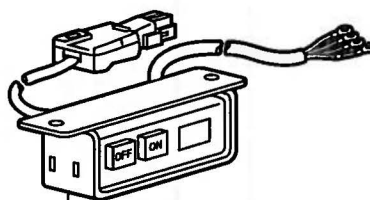

6: 三相 380V-415V
/ 3-phase 380V-415V AC

7: 用于中国三相 380V-415V
/ For China 3-phase 380V-415V AC

8: 用于日本三相 200V
/ For Japan 3-phase 200V AC

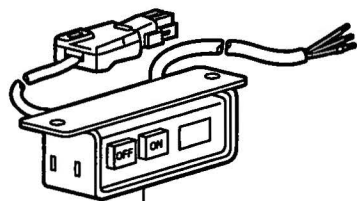

3: 单相 220V-240V
/ 1-phase 220V-240V AC

4: 用于中国单相 220V-240V
/ For China 1-phase 220V-240V AC

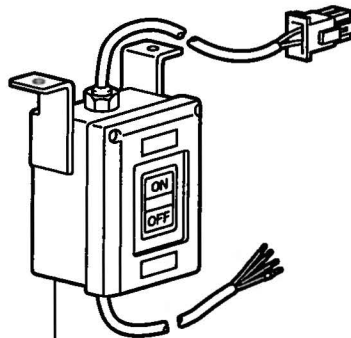

9: 三相 220V-240V
/ 3-phase 220V-240V AC

U. 电气部品(开关)装置 / Power supply equipment mechanism

参照号	零部件序号	数量	零部件名称	NAME OF PARTS	RM
1	J04086001	1	<用于日本 单相100V> 电源开关组件 1-100V#6	< For Japan, Single phase 100V AC > POWER SWITCH ASSY, 1-100V #6	
2	J04090001		<单相110V> OCR开关组件 1-110V#6	< Single phase 110V AC > OCR SWITCH ASSY, 1-110V #6	
3	J04093001	1	<单相220V-240 V > 电源开关组件 1-240V#6	< Single phase 220V-240V AC > POWER SWITCH ASSY, 1-240V #6	
4	J04251001	1	<用于中国 单相220V-240 V > 电源开关组件 1-240V#CC	< For China, Single phase 220V-240V AC > POWER SWITCH ASSY,1-240V#CCC	
5	J04134001	1	<用于欧洲 单相220V-240 V > 电源插头组件 1-240V#6	< For Europe, Single phase 220V-240V AC > POWER PLUG ASSY, 1-240V #6	
6	J04096001	1	<三相380V-415V> 电源开关组件 3-400V#6	< Three phase 380V-415V AC > POWER SWITCH ASSY,3-400V#6	
7	J04255001	1	<三相380V-415V> 电源开关组件 3-400V#CC	< For China, Three phase 380V-415V AC > POWER SWITCH ASSY,3-400V#CCC	
8	J04149001	1	<用于日本 三相200V> 电源开关组件 3-200V#6	< For Japan, Three phase 200V AC > POWER SWITCH ASSY,3-200V#6	
9	J04113001	1	<三相220V-240V> OCR开关组件 3-240V#6	< Three phase 220V-240V AC > OCR ASSY, 3-240V #6	

V. 电磁抬压脚组件装置(选购件) / Presser foot lifting solenoid set mechanism (Option parts)

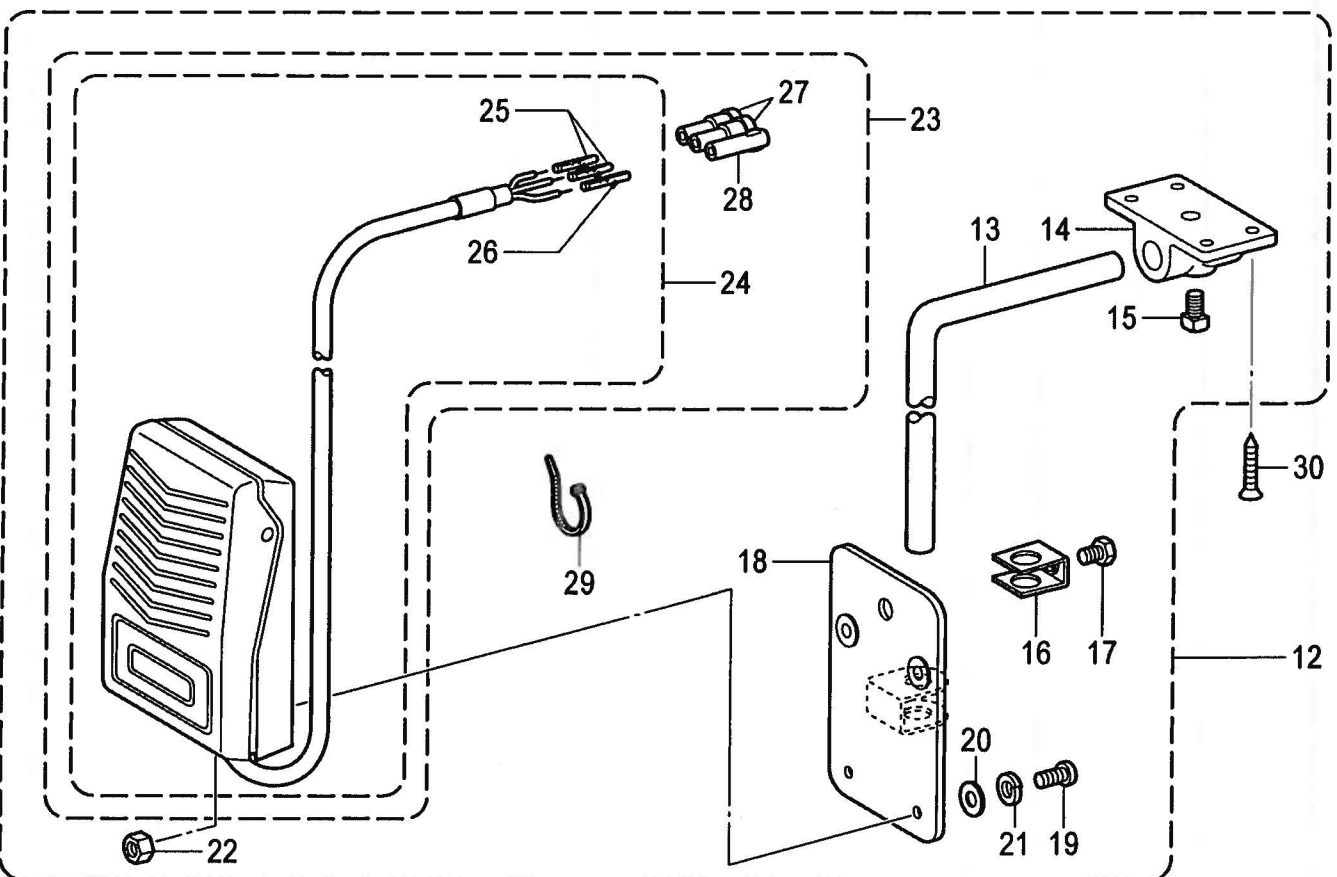
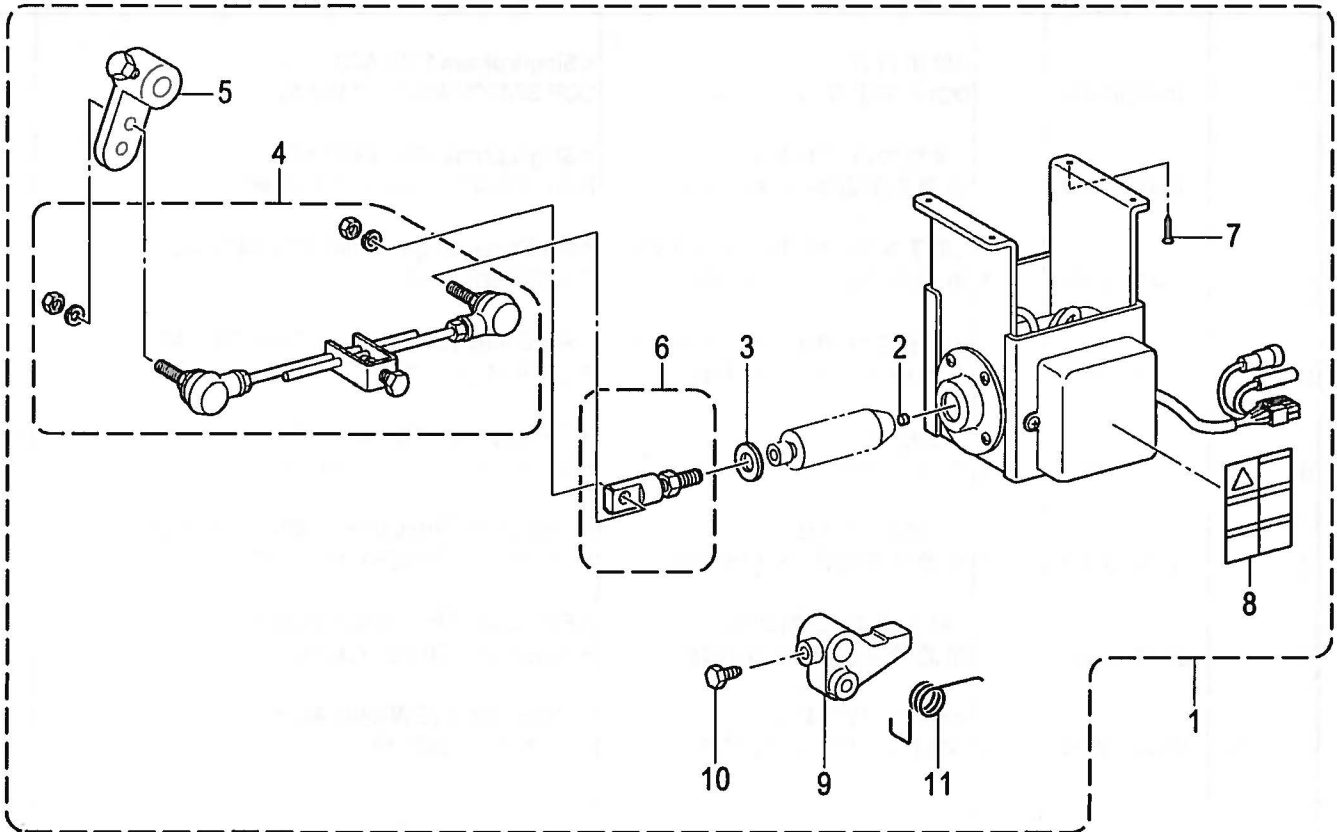

V. 电磁抬压脚组件装置 (选配件) / Presser foot lifting solenoid set mechanism (Option parts)

参照号	零部件序号	数量	零部件名称	NAME OF PARTS	RM
1	SA2707001	1	电磁抬压脚复合件 D2	P-FOOT LIFTER SOLENOID SET, D2	
2	S54025001	1	橡皮垫	CUSHION	
3	S54024001	1	橡皮垫圈	CUSHION RING	
4	S42198051	1	抬压脚杆组件	PRESSER FOOT LIFTER ROD ASSY	
5	S42199051	1	抬压脚手柄组件	P-FOOT LIFTER LEVER ASSY	
6	S41955051	1	连杆接头组件	ROD JOINT ASSY	
7	S42200051	4	木螺钉	WOOD SCREW	
8	S38351001	1	高温标志	LABEL, HIGH TEMP	
9	S10550001	1	抬压脚连杆	PRESSER BAR LIFTER LINK	
10	146367001	1	螺钉 SM5.95	BOLT, SM5.95	
11	S07729001	1	弹簧	SPRING, TWIST	
12	S07045009	1	膝控开关大组件	KNEE LIFTER SWITCH ASSY	
13	142026003	1	膝控开关弯杆	KNEE SWITCH SHAFT	
14	142027001	1	膝控开关弯杆座	BRACKET	
15	100463001	1	四角型螺栓 SM7.94	BOLT, SQUARE SM7.94	
16	114967001	1	碰块架	KNEE LIFTER PLATE STOPPER	
17	110087001	1	螺栓 SM5.95-28X8	BOLT, SM5.95-28X8	
18	S07027001	1	膝控开关安装板	K-LIFTER SWITCH SETTING PLATE	
19	062401006	4	螺钉 M4X10	SCREW, PAN M4X10	
20	025040233	4	平垫圈 M4	WASHER, PLAIN M 4	
21	028040243	4	弹簧垫圈 2-4	WASHER, SPRING 2-4	
22	021400164	4	六角螺母 M4	NUT, 1 M4	
23	S07030009	1	膝控开关引线组件	SWITCH & HARNESS ASSY	
24	S07031009	1	膝控开关组件	FOOT SWITCH ASSY	
25	143549000	2	接头插针	TERMINAL PIN, MALE	
26	143548000	1	接头插芯	TERMINAL PIN, FEMALE	
27	146046000	2	尼龙接头	NYLON CONNECTOR	
28	146194000	1	尼龙接头	NYLON CONNECTOR	
29	149799000	1	塑料固定带 S	BEAD BAND, S	
30	034422503	1	十字平头木螺钉 M4.1X25	WOOD SCREW, FLAT 2 M4.1X25	

11: 用于-□□3 / For "-□□3"
 用于-□□5 / For "-□□5"
 用于-□□F / For "-□□F"

10: 用于-□□3 / For "-□□3"
 用于-□□5 / For "-□□5"
 用于-□□F / For "-□□F"

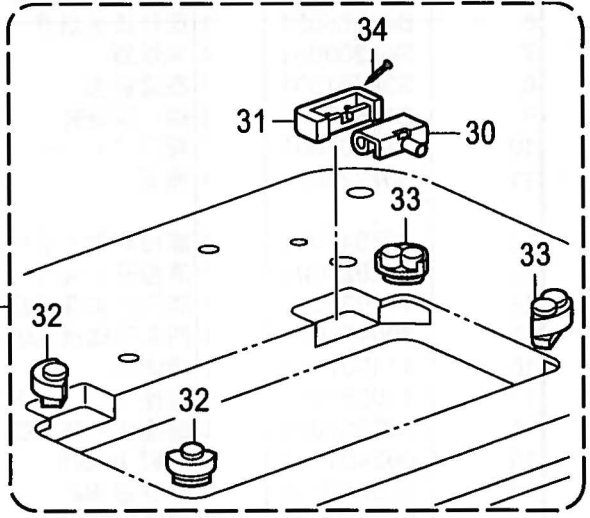
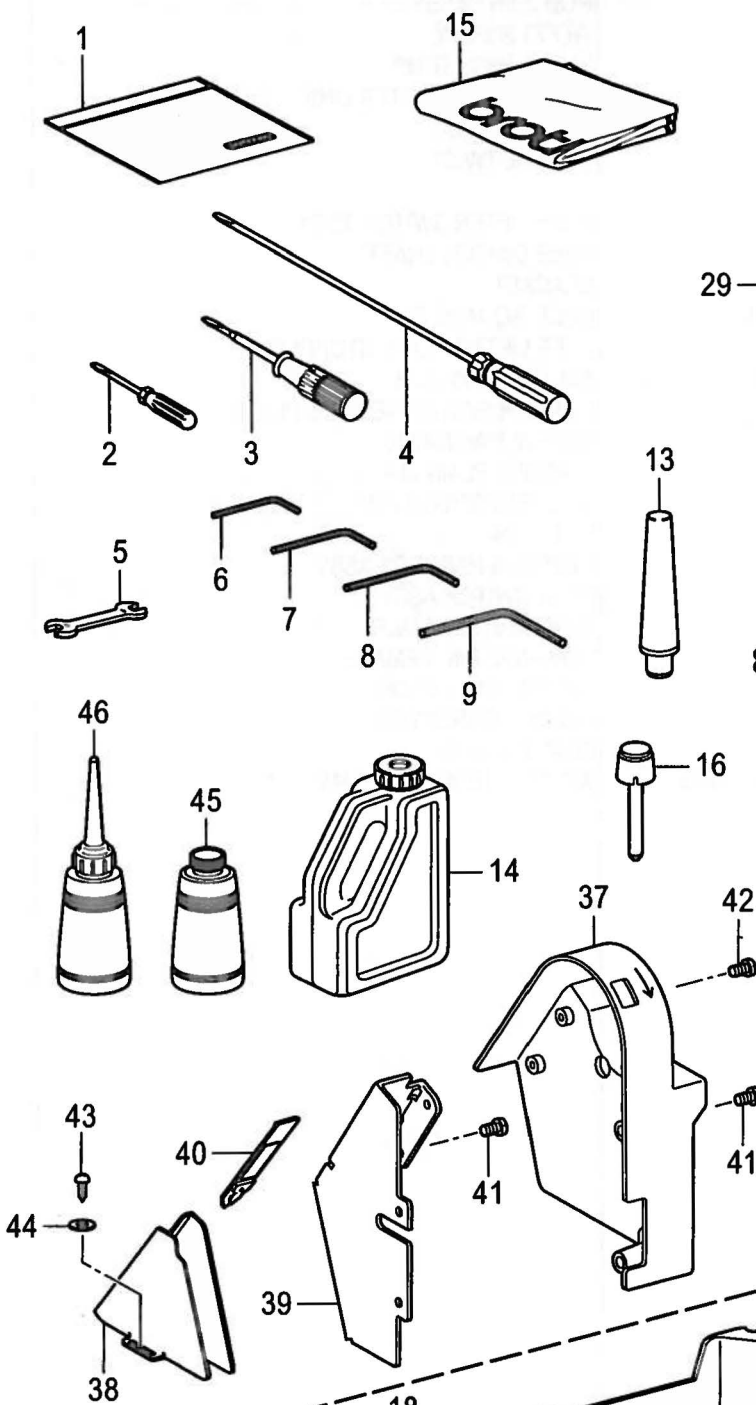

< 针杆无油型规格, 用于-□□3□
 / For "-□□3□" Semi dry type >

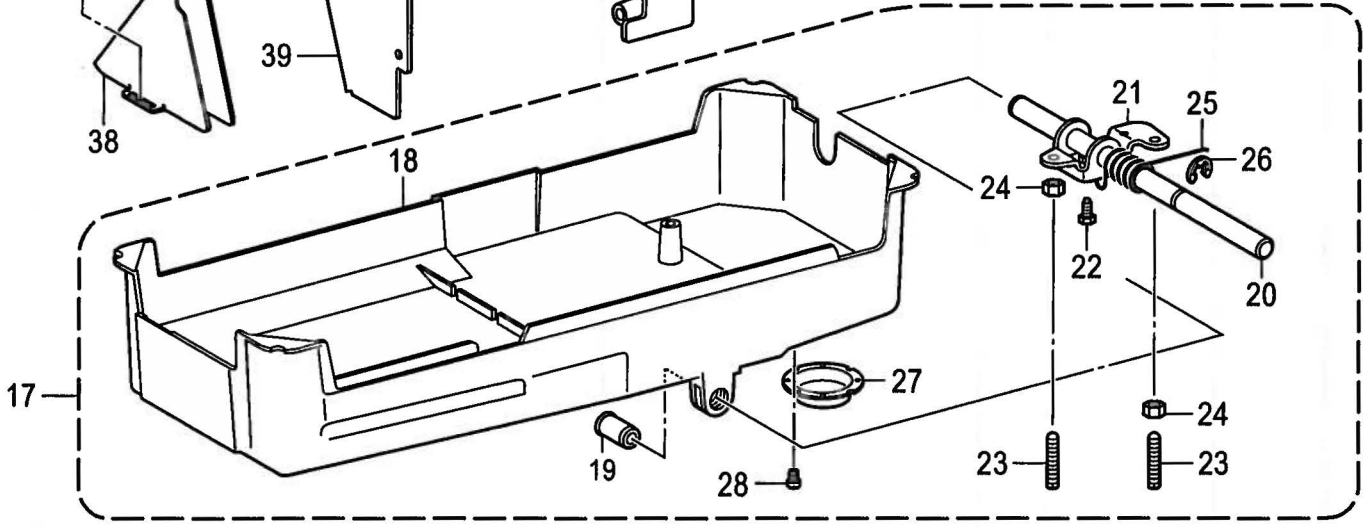
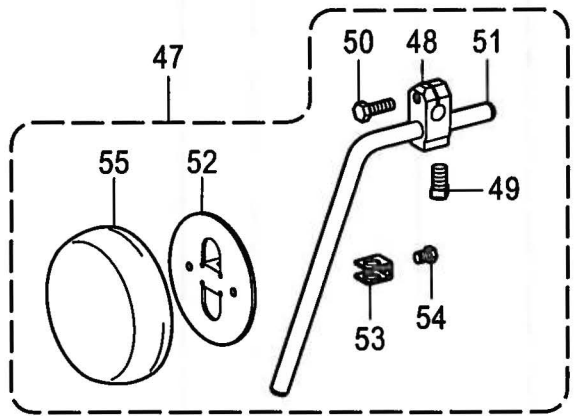

Z1 . 附件 / Accessories

参照号	零部件序号	数量	零部件名称	NAME OF PARTS	RM
1	122991001	1	附属品塑料袋	ACCESSORY BAG	
2	142443001	1	小起子 1.9X52	SCREW-DRIVER, 1.9X52	
3	118837001	1	起子 3.4X70	SCREW-DRIVER, 3.4X70	
4	S17774001	1	大起子 4.7X250	SCREW-DRIVER, 4.7X250	
5	100887001	1	双头扳手 8X9	WRENCH, 8X9	
6	142002001	1	内六角扳手 2	HEXAGONAL WRENCH, 2	
7	154125001	1	内六角扳手 2.5	HEXAGONAL WRENCH, 2.5	
8	142721001	1	内六角扳手 3	HEXAGONAL WRENCH, 3	
9	149570001	1	内六角扳手 5	HEXAGONAL WRENCH, 5	
			<用于-□□3>	<For"-□□3">	
10	SA1752014	1	机针组 107415	NEEDLE 4PIECE ASSY, 107415	
11	107415014	4	机针 DPX5(#14)	NEEDLE, DPX5	
			<用于-□□5>	<For"-□□5">	
10	SA1752022	1	机针组 107415	NEEDLE 4PIECE ASSY, 107415	
11	107415022	4	机针 DPX5(#22)	NEEDLE, DPX5	
			<用于-□□F>	<For"-□□F">	
10	SA1752011	1	机针组 107415	NEEDLE 4PIECE ASSY, 107415	
11	107415011	4	机针 DPX5	NEEDLE, DPX5	
12	S01928151	2	梭芯	BOBBIN	
13	100477009	1	机头撑杆	HEAD REST	
14	S55663001	1	油罐组件	OIL TANK ASSY	
15	S35732021	1	机头罩	HEAD COVER	
16	145573000	1	膝控提升顶杆	KNEE LIFTER COMPLYING BAR	
17	SA2691101	1	油盘组件	OIL PAN ASSY	
18	SA2692101	1	油盘	OIL PAN	
19	149578000	2	轴套	BUSH	
20	SA2582001	1	膝控横轴	KNEE LIFTER SHAFT	
21	SA2590001	1	膝控	KNEE LIFTER	
22	S25344001	1	螺栓 M6	BOLT, M6	
23	S25475001	2	螺钉 M6X19	SET SCREW, M6X19	
24	021060306	2	六角螺母 M6	NUT, 3 M6	
25	S15889001	1	复位弹簧	TWIST SPRING	
26	146293001	1	挡圈 E10	RETAINING RING, E10	
27	153230101	1	放油口	DRAIN	
28	S23418002	2	螺钉 M4X5	SCREW, M4X5	
29	SA1969001	1	橡胶铰链组件	RUBBER HINGE ASSY	
30	143882001	2	机头铰链	HEAD HINGE	
31	143910009	2	机头铰链套	RUBBER CUSHION	
32	SA1962001	2	头部防震垫	HEAD CUSHION	
33	SA1963001	2	头部防震垫	HEAD CUSHION	
34	109714000	4	钉	NAIL	
			<针杆无油型规格 用于-□3□>	<For"-□3□" semi dry type>	
35	SA2693001	1	润滑脂组件	GREASE UNIT	
36	SA2695001	1	润滑脂注入口	GREASE NOZZLE	
37	SA2768101	1	皮带罩 U	BELT COVER, U	
38	SA2769001	1	皮带罩 D	BELT COVER, D	
39	SA2770101	1	皮带罩架	BELT COVER BRACKET	
40	S37263001	1	皮带罩D盖L	BELT COVER D LID, L	
41	062500816	4	螺钉 M5X8	SCREW, PAN M5X8	
42	062500816	2	螺钉 M5X8	SCREW, PAN M5X8	
43	100666002	2	圆头木螺钉 M5.5X20	WOOD SCREW, ROUND M5.5X20	
44	025750132	2	平垫圈 S5.56	WASHER, PLAIN S 5.56	
45	114486002	1	油壶	OILER	
46	114483002	1	油壶组件	OILER ASSY	
47	S38300001	1	膝控组件	KNEE LIFTER ASSY	
48	146039001	1	碰块弯杆接头	KNEE LIFTER BRACKET	
49	100463001	1	四角型螺栓 SM7.94	BOLT, SQUARE SM7.94	
50	017762013	1	六角螺栓 SM5.95X20	BOLT, SM5.95-28X20	
51	S38278001	1	膝控弯管	KNEE LIFTER BAR	
52	S34756001	1	膝控碰块	KNEE LIFTER PLATE	
53	114967001	1	碰块架	KNEE LIFTER PLATE STOPPER	
54	110087001	1	螺栓 SM5.95-28X8	BOLT, SM5.95-28X8	
55	S31885001	1	膝控碰块垫	KNEE LIFTER PLATE COVER	

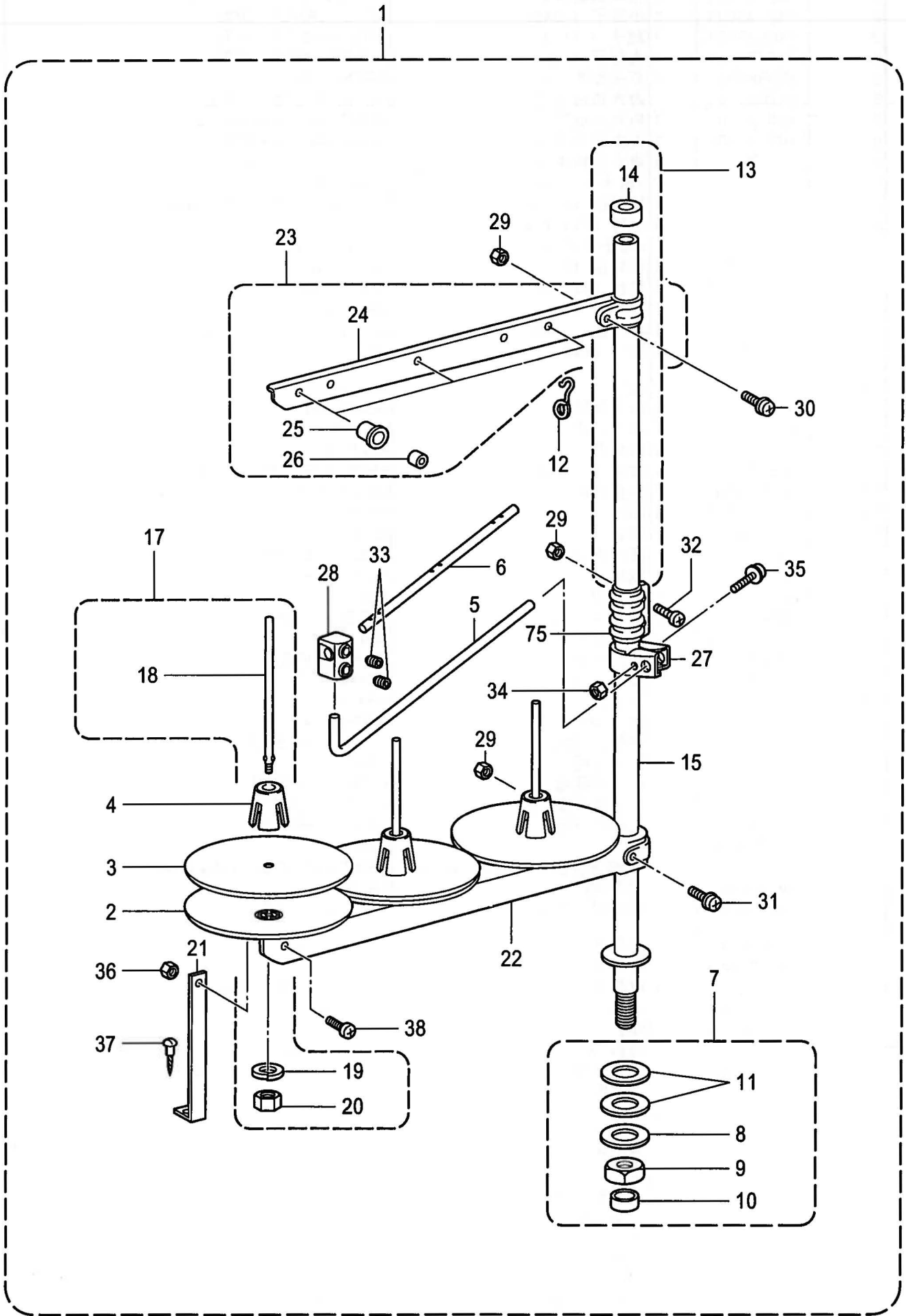

Z2 . 附件 / Accessories

参照号	零部件序号	数量	零部件名称	NAME OF PARTS	RM
1	S07558309	1	线架组件 3DRTHF	COTTON STAND ASSY, 3DRTHF	
2	S51283001	3	垫圈	SPOOL STAND BASE	
3	150182000	3	线盘软垫	SPOOL MAT	
4	S51282101	3	线轴缓冲架	SPOOL CUSHION	
5	S04109001	1	过线杆支杆	THREAD GUIDE SUPPORT BAR	
6	142997001	1	过线杆 3	THREAD GUIDE, 3	
7	SA2867001	1	管D螺母组件B	PIPE D SCREW SET, B	
8	150206002	1	平垫圈 16	WASHER, PLAIN 16	
9	S38648001	1	螺母 U5/8-28	NUT, U5/8-28	
10	150174000	1	线架支撑管套	COLUMN CAP	
11	S01005000	2	橡皮垫圈	RUBBER WASHER	
12	S02747101	1	弹簧	SPRING	
13	S40639001	1	线架撑管带管套	COLUMN PIPE W/CAP	
14	150174000	1	线架支撑管套	COLUMN CAP	
15	156112003	1	线架撑管 D	COLUMN PIPE, D	
16	150173003	1	撑管夹	COLUMN JOINT	
17	S21798001	3	线盘螺钉复合件	SPOOL & SCREW SET	
18	150179002	3	线轴 B	SPOOL SHAFT, B	
19	028050246	3	弹簧垫圈 2-5	WASHER, SPRING 2-5	
20	021500106	3	六角螺母 M5	NUT, 1 M5	
21	150188009	1	下过线架支撑板 A	SPOOL HOLDER SUPPORT, A	
22	S02779009	1	下过线架 3	SPOOL HOLDER, 3	
23	S02788009	1	上过线架3组件	THREAD HANGER ASSY, 3	
24	S02789009	1	上过线架 3	THREAD HANGER, 3	
25	150183000	3	过线管套	THREAD HANGER BASE	
26	142990001	3	过线架上过线管	THREAD BUSH	
27	150185009	1	过线杆夹头	THREAD GUIDE HOLDER	
28	138843001	1	连接器	JOINT	
29	021500106	4	六角螺母 M5	NUT, 1 M5	
30	S37038001	1	螺钉 M5X14	SCREW, PAN(S/P WASHER) M5X14	
31	S37037001	1	螺钉 M5X32	SCREW, PAN (S/P WASHER) M5X32	
32	062501406	2	螺钉 M5X14	SCREW, PAN M5X14	
33	014060632	2	固定螺钉 M6X6	SET SCREW, SOCKET (CP) M6X6	
34	021500106	1	六角螺母 M5	NUT, 1 M5	
35	S37037001	1	螺钉 M5X32	SCREW, PAN (S/P WASHER) M5X32	
36	021500106	1	六角螺母 M5	NUT, 1 M5	
37	031452206	1	圆头木螺钉 M4.5X22	WOOD SCREW, ROUND M4.5X22	
38	062501006	1	螺钉 M5X10	SCREW, PAN M5X10	

Wa. 警告标签 / Warning labels

警告标签 / Warning labels	零部件名称 / Name of parts	尺寸 / Size(mm)	零部件序号 / Code
	<p>感电标签 Label, elec. shock 6 lang</p>	<p>50 X 118</p>	<p>J04115-001</p>
	<p>操作注意标签(日 / 英) Label, caution Jpn / Eng</p>	<p>64 X 40</p>	<p>SA2040-001</p>
	<p>操作注意标签(中 / 英) Label, caution Chn / Eng</p>	<p>64 X 40</p>	<p>SA2041-001</p>
	<p>接地标记 Label, grounding</p>	<p>φ 12</p>	<p>S37060-001</p>
	<p>高温标记 Label, high temp</p>	<p>72 X 59</p>	<p>S38351-001</p>

T-8421A/8422A-Wa

Sp.不同规格零部件一览表 / Different parts list

T-8421A(无切线) / T-8421A(Without thread trimmer)

■ 旋梭 / Rotary hooks

旋梭在下列选配件中列有，请选择符合自己所需要的使用。

(零部件序号请使用旋梭放入旋梭盒内组件的零部件序号)

The following type of rotary hook are available. Select whichever one is suitable for your application.

(The following parts codes are assigned for the rotary hooks in the boxes.)

● 标准 / Normal

	用于-□□F,-□□3 / For -□□F, -□□3	用于-□□5 / For -□□5
旋梭盒组件 / Rotary hook assy	SA1668-111	SA1669-111
内梭夹 / Inner rotary hook holder	S07746-001	S07746-001
调整簧 / Tension spring	151145-001	151146-001

● 选配件 / Option

○ 附梭芯套 / Rotary hook with cap

	用于-□□F,-□□3 / For -□□F, -□□3
かま箱組 / Rotary hook assy	SA1670-111
内梭夹 / Inner rotary hook holder	S07746-001
梭芯套组件 / Bobbin case assy	S07740-001
夹线簧 / Tension spring	154518-001

○ 大面积供油 / Extra lubrication rotary hook

因供给旋梭的机油很多，可防止旋梭滚花部的磨损。适用于厚布料和极厚布料的缝纫。

Sufficient oil supplied to the rotary hook to prevent wear of the rotary hook race.

This type is suitable for sewing heavy and extra heavy materials.

	用于-□3□ /For -□3□	用于-□5□ /For -□5□
旋梭盒组件 / Rotary hook assy	SA1671-111	SA1672-111
内梭夹 / Inner rotary hook holder	S07746-001	S07747-001
调整簧 / Tension spring	151145-001	151146-001

○ 旋梭尖的强化 / Rotary hook with reinforced hook point

强化旋梭的梭尖，是为了防止旋梭梭尖部的磨损。适用于在缝制不易形成线圈的布料

(如有伸缩性的布料等)，旋梭梭尖部和机针有接触到似的使用。

The rotary hook point is reinforced to improve its durability. This type is suitable for sewing materials that are hard to make loops on the surface (like stretchy materials), and that requires making contact with the hook point and the needles.

	用于-□□F,-□□3 /For -□□F,-□□3
旋梭盒组件 / Rotary hook assy	SA1673-011
内梭夹 / Inner rotary hook holder	S07746-001
调整簧 / Tension spring	151145-001

○ RP旋梭 / RP rotary hook

因不需要供油，所以没有供油的麻烦。特别是最适用于消除布料及线的油污情况。

Lubrication is not needed. This is the most useful to prevent oil stains on material and thread.

	用于-□□F,-□□3 /For -□□F,-□□3
旋梭盒组件 / Rotary hook assy	SA1674-102
内梭夹 / Inner rotary hook holder	S07746-001
内梭组件 / Inner rotary hook assy	S36985-102
调整簧 / Tension spring	151145-001

Sp.不同规格零部件一览表 / Different parts list

T-8422A (有切线) / T-8422A(With thread trimmer)

■ 旋梭 / Rotary hooks

旋梭在下列选购件中列有，请选择符合自己所需要的使用。

(零部件序号请使用旋梭放入旋梭盒内组件的零部件序号)

The following type of rotary hook are available. Select whichever one is suitable for your application.

(The following parts codes are assigned for the rotary hooks in the boxes.)

●标准 / Normal

	全部规格 / For all type
旋梭盒组件 / Rotary hook assy	SA1677-111
内梭夹 / Inner rotary hook holder	S07748-001
调整簧 / Tension spring	151145-001

●选购件 / Option

○附梭芯套 / Rotary hook with cap

	用于-□□F,-□□3 / For -□□F,-□□3
旋梭盒组件 / Rotary hook assy	SA1678-111
内梭夹 / Inner rotary hook holder	S07749-001
梭芯套组件 / Bobbin case assy	S07740-001
夹线簧 / Tension spring	154518-001

○旋梭尖的强化 / Rotary hook with reinforced hook point

强化旋梭的梭尖，是为了防止旋梭梭尖部的磨损。适用于在缝制不易形成线圈的布料

(如有伸缩性的布料等)，旋梭梭尖部和机针有接触到似的情况下使用。

The rotary hook point is reinforced to improve its durability. This type is suitable for sewing materials that are hard to make loops on the surface (like stretchy materials), and that requires making contact with the hook point and the needles.

	用于-□□F,-□□3 /For -□□F,-□□3
旋梭盒组件 / Rotary hook assy	SA1679-011
内梭夹 / Inner rotary hook holder	S07748-001
调整簧 / Tension spring	151145-001

ORP旋梭 / RP rotary hook

因不需要供油，所以没有供油的麻烦。特别是最适用于消除布料及线的油污情况。

Lubrication is not needed. This is the most useful to prevent oil stains on material and thread.

	用于-□□F,-□□3 /For -□□F,-□□3
旋梭盒组件 / Rotary hook assy	SA3922-101
内梭夹 / Inner rotary hook holder	S07748-001
内梭组件 / Inner rotary hook assy	SA2948-101
调整簧 / Tension spring	151145-001

Ga 1. 工模具一览表 / Gauge parts list

T-8421A (用于无切线 / For without Thread trimmer)

标准品 / For Normal

- * 使用 1-1/2 (38.1mm) 的大范围工模具时, 必须对缝纫机本体等进行特别的加工。
且, 因最大针宽可达 77mm 为止, 其交货日期 □ 价格可另行商讨。
- * In case of using over 1-1/2 (38.1mm) gauge parts, it is required to make special machining on the arm-bed.
A maximum stitch width specification of 77mm is available.
Please consult your Brother representative concerning delivery date and price.

针宽 Needle gauge (mm)	针夹组件 Needle clamp assy	针板 Needle plate		送布牙 Feed dog	压脚组件 Presser foot assy
		用于中厚, 厚布料 (-3,5) 最大节距 5mm For medium & heavy materials (Max 5mm pitch)	选购 最大节距 4mm Option (Max 4mm pitch)	用于中厚, 厚布料 (-3,-5) For medium & heavy materials	
1/16 (1.6)	158808-001		142111-001	151078-001	151076-001
1/8 (3.2)	158794-101	117369-001	114950-001	114951-001	S36544-001
5/32 (4.0)	158796-101	150850-001	116503-001	116509-001	116502-001
3/16 (4.8)	158791-101	117133-001	112603-001	112659-001	SA4053-001
1/4 (6.4)	158792-101	117367-001	112604-001	112660-001	SA4049-001
5/16 (7.9)	158793-101	144882-001	112605-001	112661-001	112645-001
3/8 (9.5)	158798-101	144881-101	116506-101	116510-101	116498-001
7/16 (11.1)	158809-101		151596-001	151598-001	151597-101
1/2 (12.7)	158797-101	S09365-001	116505-001	116511-001	116499-101
5/8 (15.9)	158795-101	159577-001	116507-001	116512-001	116500-101
1 (25.4)	158805-101		147176-001	147178-001	147177-101
1-1/4 (31.8)	158799-001		116504-001	116508-001	116501-101
1-3/8 (34.9)	S10746-101	S14148-001		S14149-001	S10751-101
1-1/2 (38.1)	158800-101		118945-001	118947-001	118946-101
2 (50.8)	158802-101	144951-001		144947-001	144949-101
2-1/6 (55.0)	158803-101	147560-001		147561-001	147562-101
75mm	S16238-101		S16240-001	S16241-001	S16242-101
77mm	S30508-001		S30510-001	S30513-001	S30511-201

用于女性内衣 / For foundation

- * 针板和送布牙均为非标准品。请使用螺钉 117160-001(H-5)来安装针板。
- * The needle plate and the feed dog is different from normal parts.
- * Use part no. 117160-001(H-5) as the needle plate installation screw.

针宽 Needle gauge (mm)	(针夹组件) Needle clamp assy	针板 Needle plate	送布牙 Feed dog	(压脚组件) Presser foot assy (Without finger guard)
1/8 (3.2) 针间不隔开/ Bar	标准品 / Normal	S24571-001	S24572-001	标准品 / Normal
3/16 (4.8)		117158-001	117134-001	
1/4 (6.4)		117368-001	117365-001	
5/16 (7.9)		S31907-001	S31908-001	

用于有空缝时 / For sewing without material

- * 针板和送布牙均为非标准品。请在最大节距为 4mm 以下时使用。
- * Needle plate, the feed dog and presser foot assembly is different from normal parts.
- * Use gauge components of for sewing without material which have a maximum feed pitch of 4mm or less.

针宽 Needle gauge (mm)	(针夹组件) Needle clamp assy	针板 Needle plate	送布牙 Feed dog	压脚组件 Presser foot assy
3/16 (4.8)	标准品 / Normal	S36010-101	S36011-101	S36012-001
1/4 (6.4)		S36025-001	S36024-001	S36022-001

Ga 1 . 工模具一览表 / Gauge parts list

T-8421A (用于无切线 / For without thread trimmer)

标准品/ For Normal

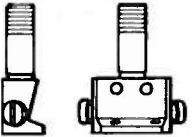
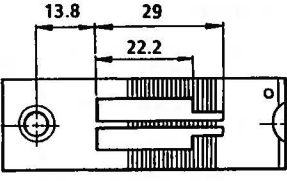
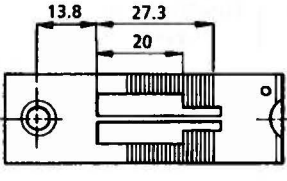
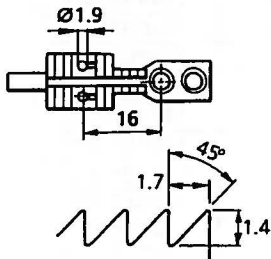
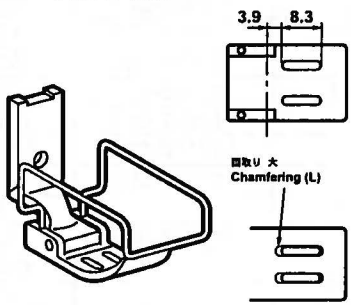
针夹组件 Needle clamp assy	针板 Needle plate	
	用于中、厚布料(-3, -5) (最大节距 5mm) For medium & heavy materials (Max 5mm pitch)	选购(最大节距 4mm) Option (Max 4mm pitch)
		
送布牙 Feed dog 用于中、厚布料(-3, -5) For medium & heavy materials	压脚组件 Presser foot assy	
		

用于女性内衣 / For foundation

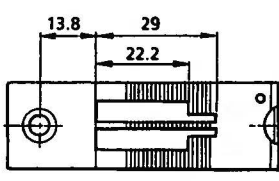
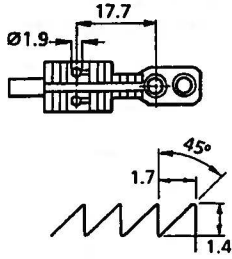
针板 Needle plate	送布牙 Feed dog
	

用于有空缝时 / For sewing without material

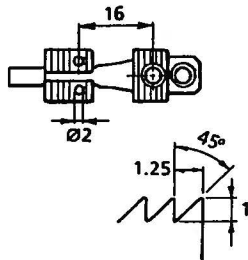
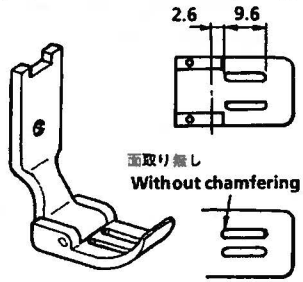
针板 Needle plate	送布牙 Feed dog	压脚组件 Presser foot assy
		

Ga 1. 工模具一览表 / Gauge parts list

T-8421A (用于无切线 / For without Thread trimmer)

用于薄布料 / For light materials

- * 送布牙为非标准品。
- * The feed dog is different from normal parts.

针宽 Needle gauge (mm)	(针夹组件) Needle clamp assy	(针板) Needle plate	送布牙 Feed dog	(压脚组件) Presser foot assy
1/8 (3.2)	标准品/ Normal	标准品/ Normal	S07880-001	标准品/ Normal
3/16 (4.8)			S07878-001	
1/4 (6.4)			S07879-001	

用于厚布料 / For heavy materials

- * 送布牙为非标准品。
- * The feed dog is different from normal parts.

针宽 Needle gauge (mm)	(针夹组件) Needle clamp assy	(针板) Needle plate	送布牙 Feed dog	(压脚组件) Presser foot assy
3/16 (4.8)	标准品/ Normal	标准品/ Normal	S21149-001	标准品/ Normal
1/4 (6.4)			S21150-001	

用于极厚布料 / For extra heavy materials

- * 送布牙为非标准品。
- * The feed dog is different from normal parts.

针宽 Needle gauge (mm)	(针夹组件) Needle clamp assy	(针板) Needle plate	送布牙 Feed dog	(压脚组件) Presser foot assy
1/8 (3.2)	标准品/ Normal	标准品/ Normal	158430-001	标准品/ Normal
3/16 (4.8)			S13588-001	
1/4 (6.4)			153882-001	
3/8 (9.5)			153887-001	
1/2 (12.7)			153892-001	
5/8 (15.9)			153897-001	

用于极薄布料 / For extra light materials

- * 送布牙和压脚组件均为非标准品。
- * 压脚组件的形状和标准品一样，但进行了特殊的表面处理。
- * The feed dog and presser foot assembly is different from normal parts.
- * The shape of the presser foot assembly is the same as for the standard part, but it has a special surface processing.

针宽 Needle gauge (mm)	(针夹组件) Needle clamp assy	(针板) Needle plate	送布牙 Feed dog	(压脚组件) Presser foot assy
3/16 (4.8)	标准品/ Normal	标准品/ Normal	S36832-001	S36833-001
1/4 (6.4)			S36829-001	S36830-001

Ga 1. 工模具一览表 / Gauge parts list

T-8421A (用于无切线 / For without Thread trimmer)

选购件 Option parts

* 压脚组件为非标准品。带导向压脚请在最大节距为 4mm 以下时使用。

* The presser foot assembly is different from normal parts.

* The presser foot assembly with guide should be used with a maximum feed pitch of 4mm or less.

零部件名称 Name of parts	针宽 Needle gauge (mm)	(针夹组件) Needle clamp assy	(针板) Needle plate	(送布牙) Feed dog	压脚组件 Presser foot assy
带导向压脚组件 Presser foot assy with guide	1/8 (3.2)	标准品 / Normal	标准品 / Normal	标准品 / Normal	149311-001
	3/16 (4.8)				117281-001
	1/4 (6.4)				149312-001
带左导向压脚组件 Presser foot assy with guide, L	5/16 (7.9)				S13735-001
用于缝制右拉链时(R) Presser foot assy for attach zipper (Right)	1/8 (3.2)				S14080-001
用于缝制左拉链时(L) Presser foot assy for attach zipper (Left)	1/8 (3.2)				S33459-001

Ga 1. 工模具一览表 / Gauge parts list

T-8421A (用于无切线 / For without Thread trimmer)

用于薄布料 / For light materials

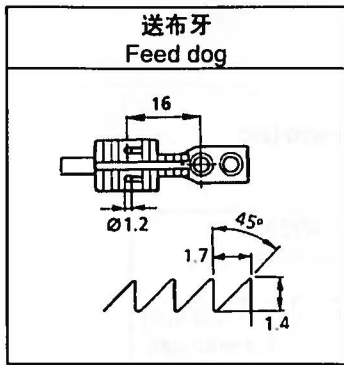

用于厚布料 / For heavy materials

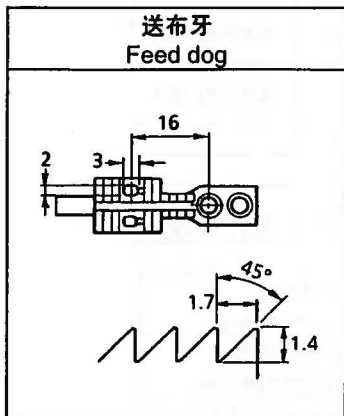

用于极厚布料 / For extra heavy materials

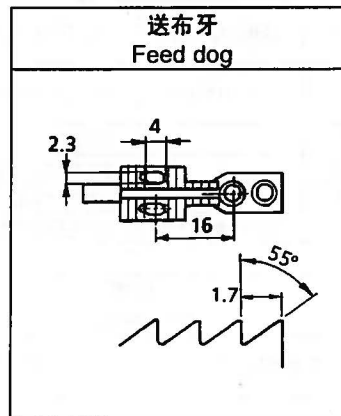

用于极薄布料 / For extra light materials

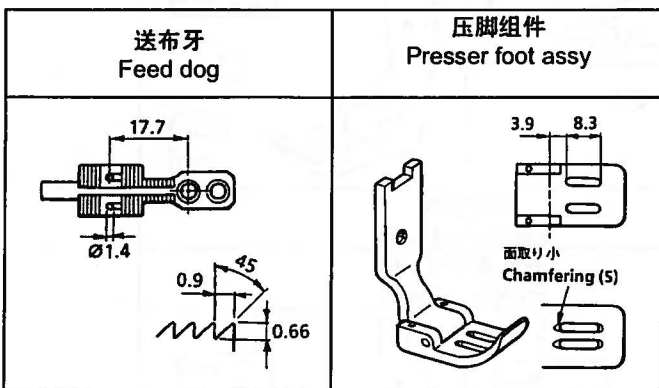

选购件 / Option parts

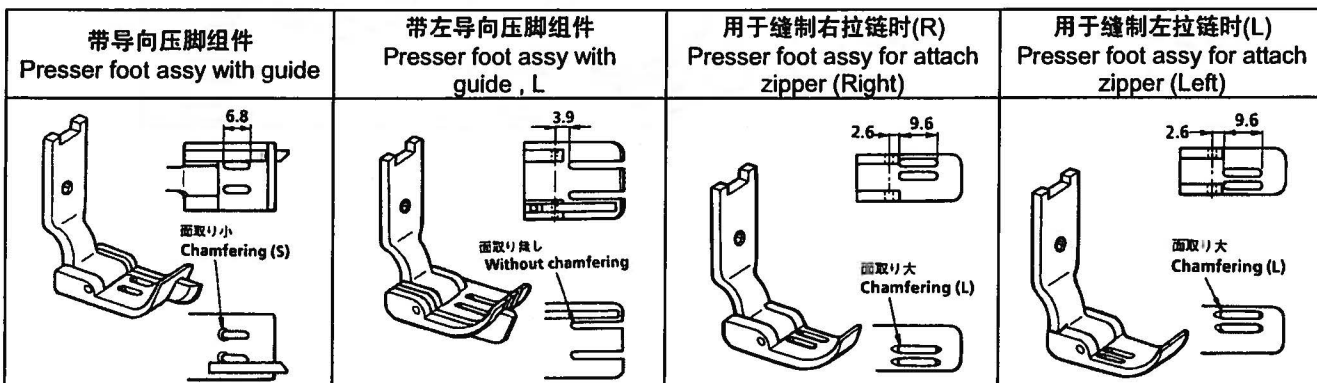

Ga 1. 工模具一览表 / Gauge parts list

T-8421A (用于无切线 / For without Thread Trimmer)

用于下送布 / For drop Feed

* 使用 1-1/2 (38.1mm) 的大范围工模具时, 必须对缝纫机本体等进行特别的加工。

且, 因最大针宽可达 77mm 为止, 其交货日期 □ 价格可另行商讨。

* In case of using over 1-1/2" (38.1 mm) gauge parts, it is necessary to make special machining on the arm-bed.

The specification with a maximum stitch width of 77 mm is available.

Please consult your Brother representative concerning delivery date and price.

针宽 Needle gauge (inch) (mm)	针夹组件 Needle clamp assy	针板 Needle plate		送布牙 Feed dog		压脚组件 Presser foot assy	
		用于薄布料(-1) For light materials	用于极薄布料 For extra light materials	用于薄布料(-1) For light materials	用于极薄布料 For extra light materials	用于薄布料(-1) For light materials	用于极薄布料 For extra light materials
1/8 (3.2)	158794-101	S07686-001		S07696-001		S38544-001	
3/16 (4.8)	158791-101	S07688-001	S36842-001	S07698-001	S36838-001	S38542-001	S36839-001
1/4 (6.4)	158792-101	S07689-001	S36841-001	S07699-001	S36835-001	S38543-001	S36836-001
1/2 (12.7)	158797-101	S07693-001		S07703-001		S07684-101	
3/4 (19.1)	158806-101	S07996-001		S07998-001		S07889-101	
20mm	S00937-00	S13479-001		S07998-001		S13480-101	
7/8 (22.2)	158807-101	S07997-001	S37011-001	S07999-001	S07999-001	S07894-101	S37012-001

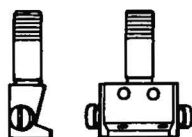
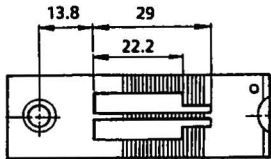
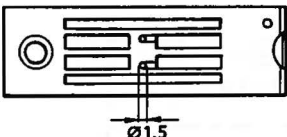
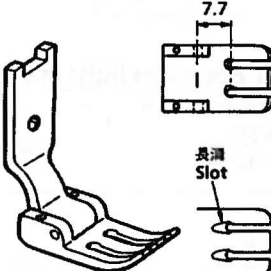
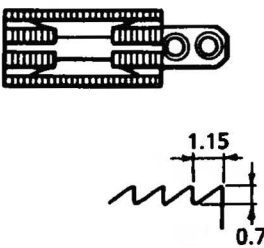
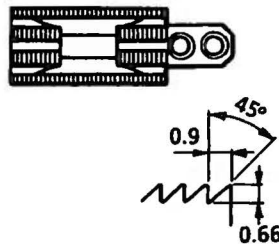
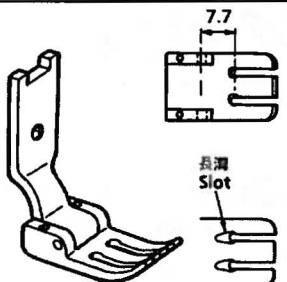
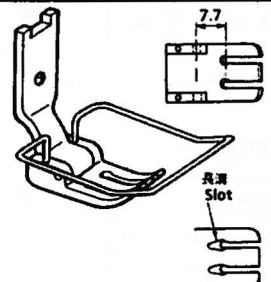
针夹组件 Needle clamp assy	针板 Needle plate		压脚组件 Presser foot assy	
	用于薄布料(-1)	用于极薄布料	用于极薄布料 For extra light materials	
				
送布牙 Feed dog		压脚组件 Presser foot assy		
用于薄布料(-1)	用于极薄布料	用于薄布料(-1) For light materials		
				

Ga 1. 工模具一览表 / Gauge parts list

T-8421A (用于无切线 / For without thread trimmer)

用于前襟 / For shirt fronts

针宽 Needle gauge mm	针夹组件 Needle clamp assy	针板 Needle plate 用于薄布料(-1) For light materials	送布牙 Feed dog 用于薄布料(-1) For light materials	压脚组件 Presser foot assy 用于薄布料(-1) For light materials
18mm	S14352-001	S14354-001	S14357-001	S14355-101
20mm	S00937-001	S13479-001	S14360-001	S14358-101
22mm	158807-001	S07997-001	S14363-001	S14361-101
24mm	S14364-001	S14366-001	S14369-001	S14367-101
26mm	S14370-001	S14372-001	S14375-001	S14373-101
28mm	S14376-001	S14378-001	S14381-001	S14379-101
30mm	S16651-001	S16653-001	S16656-001	S16654-101

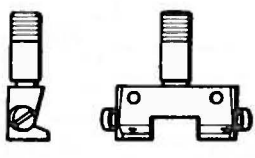
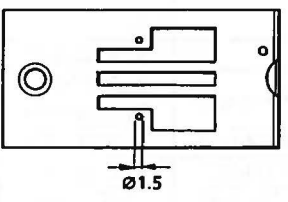
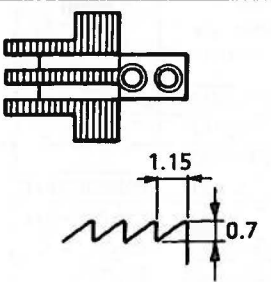
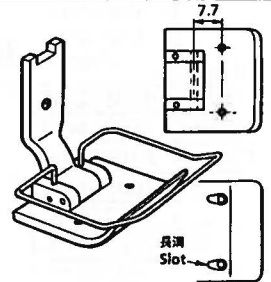
针夹组件 Needle clamp assy	针板 Needle plate 用于薄布料(-1) For light materials	送布牙 Feed dog 用于薄布料(-1) For light materials	压脚组件 Presser foot assy 用于薄布料(-1) For light materials
			

Ga 2 . 工模具一览表 / Gauge parts list

T-8422A (用于有切线 / For with Thread trimmer)

标准品 / For Normal

- * 切线用的定刀(S07527-001)和安装定刀用的螺钉(148539-101)没有附在针板上, 如需要的话, 请另行订货。
- * 使用 1-1/2 (38.1mm)的大范围工模具时, 必须对缝纫机本体等进行特别的加工。
且、因最大针宽可达 77mm 为止, 其交货日期 □价格可另行商讨。
- * The thread trimming fixed knife (part no. S07527-001) and the installation screw (part no. 148539-101) are not provided with the needle plate, so they must be ordered separately if required.
- * In case of using over 1-1/2 (38.1mm) gauge parts, it is required to make special machining on the arm-bed. A maximum stitch width specification of 2 (50.8mm) is available. Please consult your Brother representative concerning delivery date and price.

针宽 Needle gauge (mm)	针夹组件 Needle clamp assy For medium & heavy materials (Max 5mm pitch)	针板 Needle plate		送布牙 Feed dog		压脚组件 Presser foot assy	
		用于中厚, 厚布料 (-3, 5) 最大节距 5mm For medium & heavy materials (Max 5mm pitch)	选购 最大节距 4mm Option (Max 4mm pitch)	用于中厚布料(-3) For medium materials	用于厚布料(-5) For heavy materials	用于中厚布料(-3) For medium materials	用于厚布料(-5) For heavy materials
2mm	S19862-001	S19864-001			S19866-001		S19867-001
3/32 (2.4)	158804-101	159398-001			148697-001		148679-001
2.8mm	S19905-001	S19907-001			S19909-001		S19910-001
1/8 (3.2)	158794-101	155722-001	159400-001	148698-001	148699-001	S36550-001	S36552-001
5/32 (4.0)	158796-101	155724-001	158785-001	148700-001	148701-001	148689-001	148683-001
3/16 (4.8)	158791-101	155851-001	158784-001	148702-001	148703-001	S36554-001	S36556-001
1/4 (6.4)	158792-101	155853-001	158783-001	148704-001	148705-001	SA4051-001	SA4050-001
5/16 (7.9)	158793-101	155855-001	159402-001	149692-001	149691-001	149689-001	149687-001
3/8 (9.5)	158798-101	155857-001	149946-001	149939-001	149938-001	149942-001	149940-001
7/16 (11.7)	158809-101			S01646-001			S01641-101
1/2 (12.7)	158797-101	149677-001	159404-001	149676-001	149675-001	149673-101	149671-101
5/8 (15.9)	158795-101	149954-001	149956-001	149949-001	149948-001	149952-101	149950-101
3/4 (19.1)	158806-101	150526-001			150523-001		150524-101
7/8 (22.2)	158807-101	150534-001			150531-001		150532-101
1 (25.4)	158805-101	149966-001	S32052-001	S32054-001	149960-001	S32055-101	149962-101
1-1/8 (28.6)	S16102-001		S16104-001	S16106-001		S16107-101	
1-1/2 (38.1)	158800-101	S07391-001			S07390-001		S07388-101

用于有空缝时 / For sewing without material

- * 针板和送布牙均为非标准品。请在最大节距为 4mm 以下时使用。
- * Needle plate, the feed dog and presser foot assembly is different from normal parts.
- * Use gauge components of for sewing without material which have a maximum feed pitch of 4mm or less.

针宽 Needle gauge (mm)	(针夹组件) Needle clamp assy	针板 Needle plate	送布牙 Feed dog	压脚组件 Presser foot assy
3/16 (4.8)	标准品 / Normal	S20901-001	S20905-001	S20903-001
1/4 (6.4)		S10507-001	S10509-101	S10510-001
7/8 (22.2)		S14538-001	S14540-001	S14541-101
1 (25.4)		S14543-001	S14545-001	S14546-101

Ga 2 . 工模具一览表 / Gauge parts list

T-8422A (用于有切线 / For with Thread trimmer)

标准品 / For Normal

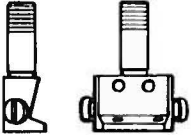
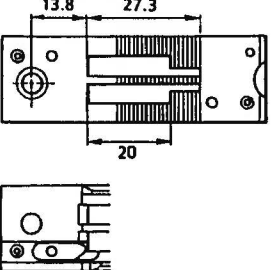
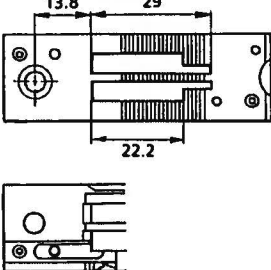
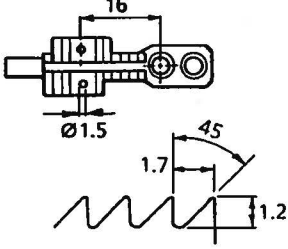
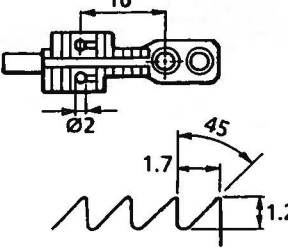
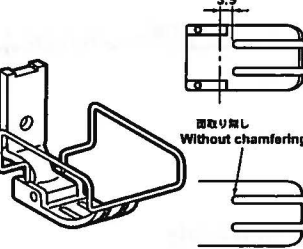
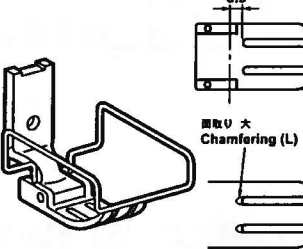
针夹组件 Needle clamp assy	针板 Needle plate		送布牙 Feed dog		压脚组件 Presser foot assy	
	用于中厚布料(-3) For medium materials	用于厚布料(-5) For heavy materials	用于中厚布料(-3) For medium materials	用于厚布料(-5) For heavy materials	用于中厚布料(-3) For medium materials	厚物用(-5) For heavy materials
						

用于有空缝时 / For sewing without material

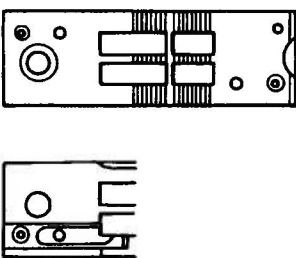
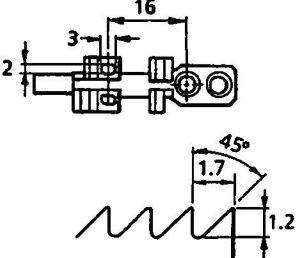
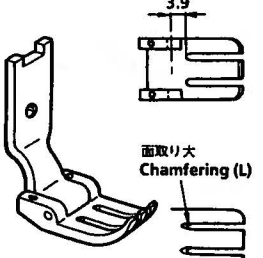
针板 Needle plate	送布牙 Feed dog	压脚组件 Presser foot assy
		

Ga 2 . 工模具一览表 / Gauge parts list T-8422A (用于有切线 / For Thread trimmer)

用于厚布料 / For heavy materials

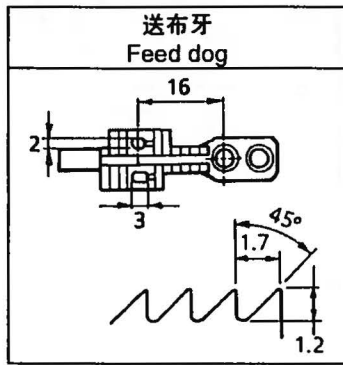

- * 送布牙为非标准品。
- * The feed dog is different from normal parts.

针宽 Needle gauge (mm)	(针夹组件) Needle clamp assy	(针板) Needle plate	送布牙 Feed dog	(压脚组件) Presser foot assy
3/16 (4.8)	标准品/ Normal	标准品/ Normal	S07905-001	标准品/ Normal
1/4 (6.4)			158756-001	

用于极薄布料 / For extra light materials

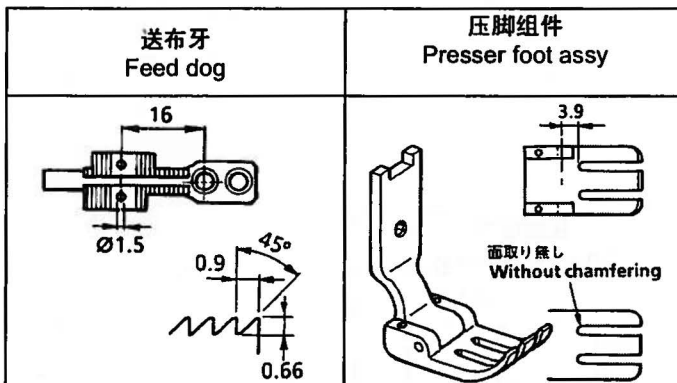

- * 送布牙和压脚组件均为非标准品。
- * The feed dog and presser foot assembly is different from normal parts.
- * 压脚组件的形状和标准品一样，但进行了特殊的表面处理。
- * The shape of the presser foot assembly is the same as for the standard part, but it has a special surface processing.

针宽 Needle gauge (mm)	(针夹组件) Needle clamp assy	(针板) Needle plate	送布牙 Feed dog	压脚组件 Presser foot assy
3/16 (4.8)	标准品/ Normal	标准品/ Normal	S36855-001	S36856-001
1/4 (6.4)			S36858-001	S36859-001

Ga 2. 工模具一览表 / Gauge parts list

T-8422A (用于有切线 / For with Thread Trimmer)

用于下送布 / For Drop Feed

*切线用的定刀(S07527-001) 和安装定刀用的螺钉(148539-101) 没有附在针板上, 如需要的话, 请另行订货。

*使用 1-1/2 (38.1mm) 的大范围工模具时, 必须对缝纫机本体等进行特别的加工。

且, 因最大针宽可达 77mm 为止, 其交货日期 □价格可另行商讨。

*The thread trimming fixed knife (part No. S07527-001) and the installation screw (part No. 148539-101) are not provided with the needle plate, so they must be ordered separately if required.

*In case of using over 1-1/2" (38.1 mm) gauge parts, it is necessary to make special machining on the arm-bed.

The specification with a maximum stitch width of 77 mm is available.

Please consult your Brother representative concerning delivery date and price.

针宽 Needle gauge (inch) (mm)	针夹组件 Needle clamp assy	针板 Needle plate		送布牙 Feed dog		压脚组件 Presser foot assy	
		用于薄布料(-1) For light materials	用于极薄布料 For extra light materials	用于薄布料(-1) For light materials	用于极薄布料 For extra light materials	用于薄布料(-1) For light materials	用于极薄布料 For extra light materials
1/8 (3.2)	158794-101	S07401-001		S07409-001		S38544-001	
3/16 (4.8)	158791-101	S07403-001	S36844-001	S07410-001	S36843-001	S38542-001	S36839-001
1/4 (6.4)	158792-101	S07405-001	S36847-001	S07411-001	S36846-001	S38543-001	S36836-001
5/16 (7.9)	158793-101	S07676-001		S07680-001		S07682-001	
3/8 (9.5)	158798-101	S13621-001		S13623-001		S13624-001	
1/2 (12.7)	158797-101	S07678-001		S07681-001		S07684-101	
3/4 (19.1)	158806-101	S07886-001		S07888-001		S07889-101	
7/8 (22.2)	158807-101	S07891-001	S37014-001	S07893-001	S07893-001	S07894-101	S37012-001
1 (25.4)	158805-101	S15088-001		S15090-001		S15091-101	
1-1/4 (38.1)	158799-001	S20914-001		S20916-001		S20917-101	

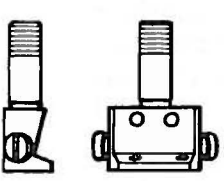
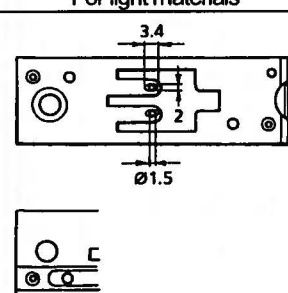
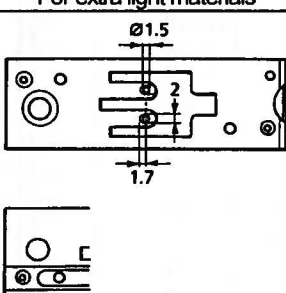
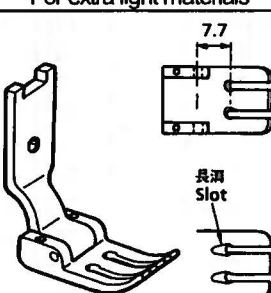
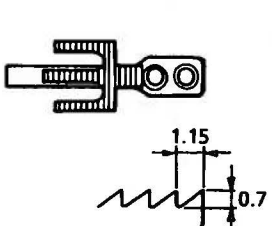
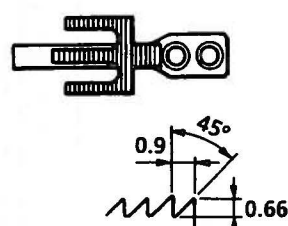
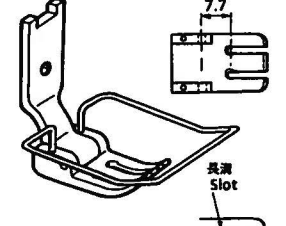
针夹组件 Needle clamp assy	针板 Needle plate		压脚组件 Presser foot assy
	用于薄布料(-1) For light materials	用于极薄布料 For extra light materials	用于极薄布料 For extra light materials
			
送布牙 Feed dog		压脚组件 Presser foot assy	
用于薄布料(-1) For light materials	用于极薄布料 For extra light materials	用于薄布料(-1) For light materials	
			

索引 / INDEX

CODE	REF.NO	Page	CODE	REF.NO	Page	CODE	REF.NO	Page	CODE	REF.NO	Page
012060636	C -39	6	026040236	T1 -8	40	062403512	B -28	4	104450101	N -17	28
	E -33	10	026050136	T1 -47	40	062500616	A -12	2		N -42	28
	F -15	12	028030246	T1 -14	40		C -16	6		N -58	28
	H -7	14	028040242	B -29	4		G -11	12	104821001	E -45	10
	P -44	32	028040243	V -21	48		G -13	12	107415011	Z1 -11	50
	R -25	36	028040245	T2 -18	42		H -40	14	107415014	Z1 -11	50
012061036	B -32	4	028050242	T1 -21	40		N -54	28	107415022	Z1 -11	50
012500536	B -20	4	028050246	T1 -46	40		Q -27	34	108801001	N -56	28
	J1 -15	16		Z2 -19	52	062500812	F -6	12	108802001	H -5	14
	J2 -14	20	031452206	Z2 -37	52	062500816	A -5	2		N -55	28
	P -31	32	034422503	V -30	48		B -34	4	109714000	Z1 -34	50
	Q -8	34	048030342	D -39	8		B -39	4	110087001	V -17	48
	Q -13	34	048040342	Q -2	34		D -2	8		Z1 -54	50
	Q -33	34		Q -14	34		E -46	10	110161004	M -1	26
	R -5	36	048060142	F -9	12		H -39	14	112603001	Ga1-	56
	S -21	38	048060342	E -18	10		M -3	26	112604001	Ga1-	56
014060632	Z2 -33	52	048070342	R -29	36		N -7	28	112605001	Ga1-	56
014400632	T1 -23	40	048090342	S -3	38		P -42	32	112645001	Ga1-	56
014500632	T1 -39	40	060300606	G -8	12		R -53	36	112659001	Ga1-	56
014500836	B -17	4	060400516	S -13	38		S -23	38	112660001	Ga1-	56
016061031	E -30	10	061350616	P -19	32		T1 -18	40	112661001	Ga1-	56
	F -13	12		P -37	32		T1 -43	40	112728001	C -8	6
017500812	R -44	36	062020806	T1 -4	40		T1 -45	40	112753001	N -64	30
017762013	Z1 -50	50	062060812	T1 -15	40		Z1 -41	50	113014000	B -7	4
018062032	C -34	6	062060816	E -7	10		Z1 -42	50	113050001	K -7	24
	C -44	6		E -52	10	062501006	Z2 -38	52	114483002	Z1 -46	50
	E -15	10		M -5	26	062501016	A -10	2	114486002	Z1 -45	50
	F -17	12		N -46	28		E -3	10	114941001	P -41	32
018062532	C -41	6		R -12	36		R -8	36	114950001	Ga1-	56
018081236	N -3	28	062061012	R -10	36		R -18	36	114951001	Ga1-	56
018501632	T1 -20	40	062061016	F -7	12		S -14	38	114967001	V -16	48
021060306	D -36	8		J2 -58	22		S -28	38		Z1 -53	50
	R -39	36		N -65	30	062501212	J2 -40	22	115947001	J1 -42	18
	Z1 -24	50	062061616	C -32	6	062501216	A -7	2		J2 -52	22
021300106	P -11	32		R -30	36		E -43	10	116010001	A -22	2
021350106	H -16	14	062300612	J1 -19	18		E -48	10	116323001	K -2	24
	R -22	36		J2 -18	20		E -53	10	116498001	Ga1-	56
021400106	T1 -10	40		J2 -18	22	062501406	Z2 -32	52	116499101	Ga1-	56
021400164	V -22	48	062300616	P -39	32	062501416	A -9	2	116500101	Ga1-	56
021500106	E -54	10		S -8	38	062661212	S -26	38	116501101	Ga1-	56
	Z2 -20	52		T1 -13	40	072600480	L -9	26	116502001	Ga1-	56
	Z2 -29	52	062350512	P -22	32	081004070	N -24	28	116503001	Ga1-	56
	Z2 -34	52	062350816	C -7	6		N -28	28	116504001	Ga1-	56
	Z2 -36	52	062351216	R -21	36	081009070	Q -5	34	116505001	Ga1-	56
021500316	J1 -12	16	062400416	J2 -65	22	081038070	N -18	28	116506101	Ga1-	56
	J2 -11	20	062400616	H -19	14	0A4261005	T1 -28	40	116507001	Ga1-	56
025040173	T2 -19	42		H -34	14	0A4300805	T1 -26	40	116508001	Ga1-	56
025040232	B -30	4		J1 -32	16		T1 -37	40	116509001	Ga1-	56
025040233	V -20	48		J1 -27	18		T2 -29	43	116510101	Ga1-	56
025050236	E -49	10		J1 -29	18	0A4400806	N -43	28	116511001	Ga1-	56
	R -45	36		J1 -32	18	0A4401005	T1 -29	40	116512001	Ga1-	56
	S -24	38		J2 -26	22		T1 -35	40	117133001	Ga1-	56
025050336	E -44	10		J2 -28	22	0A4402506	T2 -63	43	117134001	Ga1-	56
025060132	H -14	14		J2 -31	22	0A4403505	T2 -59	43	117158001	Ga1-	56
025060136	J2 -59	22		N -61	30	0A5300606	T1 -33	40	117160001	K -5	24
	Q -6	34		S -10	38	0A5501006	N -21	28	117281001	Ga1-	59
	Q -15	34		T1 -6	40	100032004	K -5	24	117365001	Ga1-	56
	T1 -16	40	062400863	T2 -17	42	100401021	Q -30	34	117367001	Ga1-	56
025060236	N -66	30	062401006	V -19	48	100463001	V -15	48	117368001	Ga1-	56
025080236	A -14	2	062401016	C -4	6		Z1 -49	50	117369001	Ga1-	56
025100132	E -37	10	062401216	Q -17	34	100477009	Z1 -13	50	118735002	C -35	6
025710132	J1 -11	16		T1 -7	40	100666002	Z1 -43	50	118837001	Z1 -3	50
025750132	Z1 -44	50	062401616	N -51	28	100887001	Z1 -5	50	118945001	Ga1-	56

CODE	REF.NO	Page	CODE	REF.NO	Page	CODE	REF.NO	Page	CODE	REF.NO	Page
118946101	Ga1-	56	148699001	Ga2-	63	153132000	F -19	12	158807101	Ga1-	61
118947001	Ga1-	56	148700001	Ga2-	63	153138001	F -10	12		Ga2-	63
118954000	E -10	10	148701001	Ga2-	63	153230101	Z1 -27	50	158808001	Ga1-	56
122991001	Z1 -1	50	148702001	Ga2-	63	153882001	Ga1-	58	158809101	Ga1-	56
138843001	Z2 -28	52	148703001	Ga2-	63	153887001	Ga1-	58		Ga2-	63
140063001	A -1	2	148704001	Ga2-	63	153892001	Ga1-	58	159398001	Ga2-	63
140647101	S -9	38	148705001	Ga2-	63	153897001	Ga1-	58	159400001	Ga2-	63
	T1 -5	40	148743001	N -33	28	154125001	Z1 -7	50	159402001	Ga2-	63
140890009	N -63	30	149095001	F -18	12	154514001	T1 -9	40	159404001	Ga2-	63
141208001	D -5	8	149311001	Ga1-	59	154518001	Sp -	54	159577001	Ga1-	56
141331002	R -35	36	149312001	Ga1-	59		Sp -	55	159805001	P -24	32
	R -37	36	149570001	Z1 -9	50	154560001	P -28	32	220681001	T2 -30	43
141544001	J2 -35	22	149578000	Z1 -19	50	154729001	F -2	12	228295001	T2 -23	42
142002001	Z1 -6	50	149671101	Ga2-	63	154730001	F -3	12		T2 -36	43
142026003	V -13	48	149673101	Ga2-	63	154731000	F -4	12	228475000	N -12	28
142027001	V -14	48	149675001	Ga2-	63	154965001	J1 -17	16	229017001	T2 -10	42
142111001	Ga1-	56	149676001	Ga2-	63		J2 -16	20		T2 -15	42
142274101	N -34	28	149677001	Ga2-	63	155510001	P -29	32		T2 -16	42
142443001	Z1 -2	50	149687001	Ga2-	63	155722001	Ga2-	63		T2 -26	42
142721001	Z1 -8	50	149689001	Ga2-	63	155724001	Ga2-	63		T2 -4	42
142990001	Z2 -26	52	149691001	Ga2-	63	155851001	Ga2-	63		T2 -37	43
142997001	Z2 -6	52	149692001	Ga2-	63	155853001	Ga2-	63		T2 -39	43
143548000	V -26	48	149799000	V -29	48	155855001	Ga2-	63		T2 -43	43
143549000	V -25	48	149938001	Ga2-	63	155857001	Ga2-	63		T2 -44	43
143611201	E -8	10	149939001	Ga2-	63	156112003	Z2 -15	52		T2 -54	43
143612100	E -9	10	149940001	Ga2-	63	158115001	L -13	26		T2 -58	43
143613051	E -16	10	149942001	Ga2-	63	158430001	Ga1-	58		T2 -62	43
143616001	E -17	10	149946001	Ga2-	63	158756001	Ga2-	65		T2 -66	44
143882001	Z1 -30	50	149948001	Ga2-	63	158769001	P -35	32	340400001	R -54	36
143910009	Z1 -31	50	149949001	Ga2-	63	158783001	Ga2-	63	414959001	T2 -40	43
144504001	P -27	32	149950101	Ga2-	63	158784001	Ga2-	63		T2 -42	43
144881101	Ga1-	56	149952101	Ga2-	63	158785001	Ga2-	63		T2 -50	43
144882001	Ga1-	56	149954001	Ga2-	63	158791101	Ga1-	56		T2 -61	43
144947001	Ga1-	56	149956001	Ga2-	63		Ga1-	61		T2 -65	44
144949101	Ga1-	56	149960001	Ga2-	63		Ga2-	63	J00353001	T2 -47	43
144951001	Ga1-	56	149962101	Ga2-	63	158792101	Ga1-	56	J00494001	T2 -38	43
145446001	P -23	32	149966001	Ga2-	63		Ga1-	61	J00953001	T2 -20	42
	Q -29	34	150173003	Z2 -16	52		Ga2-	63	J01411001	T2 -51	43
145573000	Z1 -16	50	150174000	Z2 -10	52	158793101	Ga1-	56	J01892001	T2 -24	42
146039001	Z1 -48	50		Z2 -14	52		Ga2-	63	J02039002	T2 -11	42
146046000	V -27	48	150179002	Z2 -18	52	158794101	Ga1-	56	J02195001	T2 -67	44
146194000	V -28	48	150182000	Z2 -3	52		Ga1-	61	J02568001	T2 -7	42
146293001	Z1 -26	50	150183000	Z2 -25	52		Ga2-	63	J02725001	T2 -41	43
146367001	V -10	48	150185009	Z2 -27	52	158795101	Ga1-	56	J02825001	T2 -22	42
147176001	Ga1-	56	150188009	Z2 -21	52		Ga2-	63	J03739001	T2 -34	43
147177101	Ga1-	56	150206002	Z2 -8	52	158796101	Ga1-	56	J03929001	T2 -2	42
147178001	Ga1-	56	150523001	Ga2-	63		Ga2-	63	J03930001	T2 -3	42
147560001	Ga1-	56	150524101	Ga2-	63	158797101	Ga1-	56	J03931001	T2 -6	42
147561001	Ga1-	56	150526001	Ga2-	63		Ga1-	61	J03934001	T2 -9	42
147562101	Ga1-	56	150531001	Ga2-	63		Ga2-	63	J03935001	T2 -13	42
148394000	C -14	6	150532101	Ga2-	63	158798101	Ga1-	56	J03936001	T2 -52	43
148511001	S -2	38	150534001	Ga2-	63		Ga2-	63	J03939001	T2 -53	43
148536001	R -48	36	150850001	Ga1-	56	158799001	Ga1-	56	J03955001	T1 -22	40
148539101	R -50	36	151027001	J3 -5	24	158800101	Ga1-	56	J03956001	T1 -24	40
148546001	R -14	36	151030001	J3 -4	24		Ga2-	63	J03957001	T1 -25	40
	S -15	38	151076001	Ga1-	56	158802101	Ga1-	56	J03958001	T1 -27	40
148559100	R -27	36	151078001	Ga1-	56	158803101	Ga1-	56	J03964001	T1 -38	40
148602001	J2 -61	22	151145001	Sp -	54	158804101	Ga2-	63	J03975001	T1 -51	40
148679001	Ga2-	63		Sp -	55	158805101	Ga1-	56	J03976001	T1 -52	40
148683001	Ga2-	63	151146001	Sp -	54		Ga2-	63	J03983001	T1 -55	40
148689001	Ga2-	63	151596001	Ga1-	56	158806101	Ga1-	61	J03984001	T1 -56	40
148697001	Ga2-	63	151597101	Ga1-	56		Ga2-	63	J04086001	U -1	46
148698001	Ga2-	63	151598001	Ga1-	56	158807001	Ga1-	62	J04090001	U -2	46

索引 / INDEX

CODE	REF.NO	Page	CODE	REF.NO	Page	CODE	REF.NO	Page	CODE	REF.NO	Page
J04093001	U -3	46	S02789009	Z2 -24	52	S09260001	J1 -4	16	S17774001	Z1 -4	50
J04096001	U -6	46	S04109001	Z2 -5	52		J2 -4	20	S19862001	Ga2-	63
J04097001	T2 -48	43	S05246000	N -32	28	S09261001	J1 -4	16	S19864001	Ga2-	63
J04098001	T2 -49	43	S07027001	V -18	48		J2 -4	20	S19866001	Ga2-	63
J04099001	T2 -70	44	S07030009	V -23	48	S09365001	Ga1-	56	S19867001	Ga2-	63
J04100001	T2 -33	43	S07031009	V -24	48	S10507001	Ga2-	63	S19905001	Ga2-	63
J04113001	U -9	46	S07045009	V -12	48	S10509101	Ga2-	63	S19907001	Ga2-	63
J04115001	T2 -8	42	S07346101	D -6	8	S10510001	Ga2-	63	S19909001	Ga2-	63
	Wa -	53	S07351001	D -14	8	S10550001	V -9	48	S19910001	Ga2-	63
J04134001	U -5	46	S07353001	D -13	8	S10746101	Ga1-	56	S20681000	P -25	32
J04136001	T2 -5	42	S07355051	D -27	8	S10751101	Ga1-	56	S20682105	P -26	32
J04137001	T2 -14	42	S07374109	E -39	10	S10780001	D -37	8	S20901001	Ga2-	63
J04140001	T2 -12	42	S07376001	E -50	10	S11244001	K -4	24	S20903001	Ga2-	63
J04147001	T2 -56	43	S07388101	Ga2-	63	S12441001	Q -32	34	S20905001	Ga2-	63
J04148001	T2 -57	43	S07390001	Ga2-	63	S13160001	B -15	4	S21150001	Ga1-	58
J04149001	U -8	46	S07391001	Ga2-	63	S13479001	Ga1-	61	S21449001	Ga1-	58
J04155001	T2 -35	43	S07419001	J1 -6	16		Ga1-	62	S21798001	Z2 -17	52
J04164001	T2 -21	42		J2 -6	20	S13480101	Ga1-	61	S23418002	Q -19	34
J04167001	T2 -55	43	S07420000	J1 -5	16	S13588001	Ga1-	58		Z1 -28	50
J04168001	T2 -27	42		J2 -5	20	S13735001	Ga1-	59	S23460001	C -37	6
J04169001	T2 -28	42	S07424001	S -30	38	S14080001	Ga1-	59	S23651001	B -10	4
J04195001	T1 -53	40	S07465000	C -18	6	S14148001	Ga1-	56		B -25	4
J04210001	T2 -68	44	S07488001	P -34	32	S14149001	Ga1-	56		H -9	14
J04230001	T1 -34	40	S07494001	K -9	24	S14352001	Ga1-	62		J2 -38	20
J04243001	T2 -69	44	S07509001	R -28	36	S14354001	Ga1-	62		J2 -38	22
J04251001	U -4	46	S07525000	J2 -34	22	S14355101	Ga1-	62	S24571001	Ga1-	56
J04255001	U -7	46	S07526201	R -47	36	S14357001	Ga1-	62	S24572001	Ga1-	56
J04273001	T1 -54	40	S07527001	R -49	36	S14358101	Ga1-	62	S25234001	B -3	4
J04296001	T1 -36	40	S07529001	D -15	8	S14360001	Ga1-	62	S25235001	B -11	4
J80964101	T2 -25	42		D -38	8	S14361101	Ga1-	62	S25236001	B -12	4
J80965001	T2 -31	43	S07549101	S -18	38	S14363001	Ga1-	62		E -13	10
J80966001	T2 -32	43	S07550001	S -19	38	S14364001	Ga1-	62		L -11	26
J80967001	T2 -45	43	S07552001	S -25	38	S14366001	Ga1-	62		L -15	26
J80968001	T2 -46	43	S07553001	S -29	38	S14367101	Ga1-	62		R -33	36
J80969001	T1 -48	40	S07558309	Z2 -1	52	S14369001	Ga1-	62	S25260001	B -8	4
J80970001	T2 -60	43	S07684101	Ga1-	61	S14370001	Ga1-	62		C -21	6
J80971001	T1 -30	40	S07686001	Ga1-	61	S14372001	Ga1-	62		C -28	6
J80973001	T1 -49	40	S07688001	Ga1-	61	S14373101	Ga1-	62	S25289001	D -9	8
J80974001	T1 -50	40	S07689001	Ga1-	61	S14375001	Ga1-	62	S25344001	Z1 -22	50
J80976101	T2 -1	42	S07693001	Ga1-	61	S14376001	Ga1-	62	S25475001	Z1 -23	50
J80977101	T2 -1	42	S07696001	Ga1-	61	S14378001	Ga1-	62	S25789000	Q -9	34
J80979101	T2 -1	42	S07698001	Ga1-	61	S14379101	Ga1-	62	S30508001	Ga1-	56
J80980101	T2 -1	42	S07699001	Ga1-	61	S14381001	Ga1-	62	S30510001	Ga1-	56
J80981001	T2 -1	42	S07703001	Ga1-	61	S14538001	Ga2-	63	S30511201	Ga1-	56
J80982101	T2 -1	42	S07729001	V -11	48	S14540001	Ga2-	63	S30513001	Ga1-	56
J80984101	T2 -1	42	S07740001	Sp -	54	S14541101	Ga2-	63	S31006001	D -11	8
J80985101	T2 -1	42		Sp -	55	S14543001	Ga2-	63	S31032001	Q -31	34
J80987101	T2 -1	42	S07746001	J3 -6	24	S14545001	Ga2-	63	S31885001	Z1 -55	50
J80988101	T2 -1	42		Sp -	54	S14546101	Ga2-	63	S31907001	Ga1-	56
J80989101	T2 -1	42	S07747001	Sp -	54	S15889001	Z1 -25	50	S31908001	Ga1-	56
J80990001	T1 -19	40	S07748001	Sp -	55	S16102001	Ga2-	63	S32052001	Ga2-	63
S00937001	Ga1-	61	S07749001	Sp -	55	S16104001	Ga2-	63	S32054001	Ga2-	63
	Ga1-	62	S07878001	Ga1-	58	S16106001	Ga2-	63	S32055101	Ga2-	63
S01005000	Z2 -11	52	S07879001	Ga1-	58	S16107101	Ga2-	63	S32904000	G -4	12
S01641101	Ga2-	63	S07880001	Ga1-	58	S16196001	D -6	8	S33459001	Ga1-	59
S01646001	Ga2-	63	S07889101	Ga1-	61	S16238101	Ga1-	56	S34281000	G -3	12
S01928151	J2 -60	22	S07894101	Ga1-	61	S16240001	Ga1-	56	S34438051	A -21	2
	Z1 -12	50	S07905001	Ga2-	65	S16241001	Ga1-	56	S34756001	Z1 -52	50
S02664001	S -5	38	S07996001	Ga1-	61	S16242101	Ga1-	56	S35732021	Z1 -15	50
S02665000	S -6	38	S07997001	Ga1-	61	S16651001	Ga1-	62	S36010101	Ga1-	56
S02747101	Z2 -12	52		Ga1-	62	S16653001	Ga1-	62	S36011101	Ga1-	56
S02779009	Z2 -22	52	S07998001	Ga1-	61	S16654101	Ga1-	62	S36012001	Ga1-	56
S02788009	Z2 -23	52	S07999001	Ga1-	61	S16656001	Ga1-	62	S36022001	Ga1-	56

CODE	REF.NO	Page	CODE	REF.NO	Page	CODE	REF.NO	Page	CODE	REF.NO	Page
S36024001	Ga1-	56	S51815001	N -2	28	SA2460001	B -23	4	SA2568001	J2 -57	22
S36025001	Ga1-	56		N -15	28	SA2461001	B -26	4	SA2571001	L -5	26
S36544001	Ga1-	56	S54024001	V -3	48	SA2463001	B -31	4	SA2572001	J1 -20	18
S36550001	Ga2-	63	S54025001	V -2	48	SA2464001	B -18	4		J2 -19	20
S36552001	Ga2-	63	S55663001	Z1 -14	50	SA2469001	B -33	4		J2 -19	22
S36554001	Ga2-	63	S58900000	J2 -64	22	SA2474001	C -3	6	SA2574001	J1 -21	18
S36556001	Ga2-	63	SA1120001	B -9	4	SA2475001	C -5	6		J2 -20	20
S36663051	A -20	2	SA1174001	D -3	8	SA2479001	A -17	2		J2 -20	22
S36829001	Ga1-	58	SA1175001	D -4	8		A -19	2	SA2575001	J1 -22	18
S36830001	Ga1-	58	SA1179001	D -34	8		A -28	2		J1 -24	18
S36832001	Ga1-	58	SA1360001	Q -26	34	SA2482001	C -11	6		J2 -21	20
S36833001	Ga1-	58	SA1385001	T1 -1	40	SA2483001	C -12	6		J2 -21	22
S36835001	Ga1-	61	SA1388001	G -12	12	SA2484001	C -13	6		J2 -23	22
S36836001	Ga1-	61	SA1668111	Sp -	54	SA2485001	C -20	6		L -7	26
S36838001	Ga1-	61	SA1669111	Sp -	54		C -27	6	SA2576001	J1 -23	18
S36839001	Ga1-	61	SA1670111	Sp -	54	SA2490101	C -36	6		J2 -22	20
S36841001	Ga1-	61	SA1671111	Sp -	54	SA2493001	C -42	6		J2 -22	22
S36842001	Ga1-	61	SA1672111	Sp -	54	SA2494001	C -43	6	SA2578001	D -41	8
S36855001	Ga2-	65	SA1673011	Sp -	54	SA2495001	D -1	8	SA2579001	J1 -35	18
S36856001	Ga2-	65	SA1674102	Sp -	54	SA2496001	D -7	8		J2 -44	22
S36858001	Ga2-	65	SA1677111	Sp -	55	SA2498001	D -8	8	SA2580001	L -6	26
S36859001	Ga2-	65	SA1678111	Sp -	55	SA2499001	D -10	8	SA2582001	Z1 -20	50
S36985102	Sp -	54	SA1679011	Sp -	55	SA2504001	S -20	38	SA2584001	L -8	26
S37011001	Ga1-	61	SA1752011	Z1 -10	50	SA2507001	D -31	8	SA2585001	E -12	10
S37012001	Ga1-	61	SA1752014	Z1 -10	50	SA2509001	E -1	10		L -10	26
S37037001	Z2 -31	52	SA1752022	Z1 -10	50	SA2511001	E -2	10		L -14	26
	Z2 -35	52	SA1962001	Z1 -32	50	SA2512001	E -4	10	SA2587001	L -12	26
S37038001	Z2 -30	52	SA1963001	Z1 -33	50	SA2515001	E -5	10	SA2590001	Z1 -21	50
S37060001	A -25	2	SA1969001	Z1 -29	50	SA2516001	E -6	10	SA2596001	N -40	28
	Wa -	53	SA1971101	Q -1	34	SA2518001	E -11	10	SA2597001	N -39	28
S37263001	Z1 -40	50	SA1975001	Q -3	34	SA2521001	E -14	10	SA2598001	N -41	28
S38212001	J1 -16	16	SA1978001	Q -4	34	SA2526001	E -31	10	SA2599001	N -23	28
	J2 -15	20	SA1980001	Q -7	34	SA2527001	E -32	10		N -27	28
S38266000	N -9	28	SA1981101	Q -10	34	SA2531001	E -40	10	SA2604001	N -52	28
S38274001	P -32	32	SA1982101	Q -11	34	SA2532001	E -47	10	SA2605001	N -53	28
S38278001	Z1 -51	50	SA1983001	Q -12	34	SA2533001	E -51	10	SA2606101	N -57	28
S38300001	Z1 -47	50	SA1984001	Q -16	34	SA2535101	F -5	12	SA2607001	P -1	32
S38351001	V -8	48	SA1985001	Q -18	34	SA2536001	F -11	12	SA2613001	P -4	32
	Wa -	53	SA1988001	Q -20	34	SA2539001	F -16	12	SA2614001	P -5	32
S38398001	B -5	4	SA1989001	Q -21	34	SA2540001	F -12	12	SA2615001	P -6	32
S38421001	S -22	38	SA1990101	Q -22	34	SA2543001	H -4	14	SA2619001	P -7	32
S38426000	S -4	38	SA1991001	Q -23	34	SA2544001	H -6	14	SA2620001	P -9	32
S38481000	L -2	26	SA1992101	Q -25	34	SA2546001	H -8	14	SA2621001	P -10	32
	L -4	26	SA1994001	Q -28	34	SA2549001	H -37	14	SA2623001	P -8	32
S38542001	Ga1-	61	SA1998001	R -52	36	SA2552001	H -38	14	SA2624001	P -13	32
S38543001	Ga1-	61	SA2040001	A -26	2	SA2553001	H -17	14	SA2625001	P -14	32
S38544001	Ga1-	61		Wa -	53	SA2554001	H -18	14	SA2626001	P -12	32
S38648001	Z2 -9	52	SA2041001	A -26	2	SA2556001	J1 -41	18		P -15	32
S38687000	R -51	36	SA2041002	Wa -	53		J2 -51	22	SA2627001	P -16	32
S38707001	B -4	4	SA2165001	D -33	8		J2 -55	22	SA2628001	P -17	32
S38710001	B -24	4	SA2190001	Q -24	34	SA2557001	J1 -7	16	SA2629001	P -18	32
S38713100	B -27	4	SA2270001	G -2	12		J2 -7	20	SA2630001	P -21	32
S38744101	T1 -2	40	SA2354001	T1 -40	40	SA2558001	J2 -63	22	SA2632001	P -30	32
S39048001	S -7	38	SA2378001	R -32	36	SA2560001	J1 -10	16	SA2633001	P -33	32
S39051001	D -12	8	SA2440001	A -3	2		J2 -10	20	SA2634001	P -36	32
S40639001	Z2 -13	52	SA2441001	A -6	2	SA2562101	J1 -18	16	SA2635001	P -38	32
S41955051	V -6	48	SA2442001	A -8	2		J2 -17	20	SA2636001	P -43	32
S42198051	V -4	48	SA2443001	A -11	2	SA2563101	J1 -34	18	SA2637001	P -45	32
S42199051	V -5	48	SA2444101	A -13	2		J2 -43	22	SA2638001	P -46	32
S42200051	V -7	48	SA2445001	A -15	2	SA2565001	J1 -44	18	SA2639001	P -40	32
S48367000	E -42	10	SA2447001	A -16	2		J2 -54	22	SA2640001	P -47	32
S51282101	Z2 -4	52	SA2449001	A -18	2	SA2566001	H -15	14	SA2642001	R -1	36
S51283001	Z2 -2	52	SA2452101	B -1	4	SA2567001	J2 -56	22	SA2643001	R -2	36

索引 / INDEX

CODE	REF.NO	Page	CODE	REF.NO	Page	CODE	REF.NO	Page	CODE	REF.NO	Page
SA2644001	R -3	36	SA2824001	P -20	32	SA3859001	J2 -9	20	SA4215001	N -10	28
SA2645001	R -4	36	SA2825001	J1 -40	18	SA3864001	H -11	14	SA4335001	B -6	4
	R -46	36		J2 -50	22	SA3867001	H -11	14	UK3745000	T2 -64	43
SA2646001	R -6	36	SA2826001	J2 -41	22	SA3886001	H -12	14			
SA2647001	R -9	36	SA2827001	J2 -62	22	SA3889001	J1 -13	16			
SA2648001	R -11	36	SA2859000	R -17	36		J2 -12	20			
SA2651001	R -13	36	SA2860001	R -16	36		L -1	26			
SA2652101	R -15	36	SA2861001	B -13	4	SA3891001	L -3	26			
SA2653001	R -19	36	SA2867001	Z2 -7	52	SA3894001	J1 -31	18			
SA2655001	R -20	36	SA2927001	H -13	14		J2 -30	22			
SA2657001	R -23	36	SA2929001	A -4	2	SA3896001	N -22	28			
SA2658001	R -24	36		A -23	2	SA3898001	N -26	28			
SA2659001	R -26	36		A -24	2	SA3912001	J2 -36	20			
SA2661001	R -31	36		N -8	28		J2 -36	22			
SA2663001	R -34	36		N -16	28	SA3916001	J1 -39	18			
SA2665001	R -36	36	SA2935101	B -14	4		J2 -49	22			
SA2667001	R -38	36	SA2936101	B -14	4	SA3922101	Sp -	55			
SA2668001	R -40	36	SA2948101	Sp -	55	SA3923001	N -50	28			
SA2669001	R -41	36	SA2950101	J1 -1	16	SA3924001	A -2	2			
SA2670001	J2 -47	22		J1 -33	16	SA3946001	N -4	28			
SA2671001	J2 -39	20	SA2956001	N -5	28	SA3949001	N -14	28			
SA2672001	R -42	36	SA2957001	N -6	28	SA3953001	J2 -1	20			
SA2673001	R -43	36	SA2958001	B -19	4	SA3961001	J1 -2	16			
SA2675001	J2 -37	20	SA2992001	F -8	12		J2 -2	20			
	J2 -37	22		F -14	12	SA3965001	H -2	14			
SA2676001	J2 -33	22	SA3025001	T1 -41	40	SA3988001	J1 -38	18			
SA2677001	D -40	8	SA3037001	N -35	28		J2 -48	22			
SA2678001	M -2	26	SA3040001	N -36	28	SA3990001	H -20	14			
SA2679001	M -4	26	SA3044001	N -47	28	SA4007001	C -15	6			
SA2680001	S -1	38	SA3045101	N -44	28	SA4011001	H -36	14			
SA2682001	S -16	38	SA3046001	N -45	28	SA4012001	J1 -30	18			
SA2683001	S -17	38	SA3047001	N -49	28		J2 -29	22			
SA2684001	S -27	38	SA3048101	N -59	28	SA4014001	N -62	30			
SA2686001	T1 -3	40	SA3049001	N -60	30	SA4026001	J1 -14	16			
SA2687001	T1 -42	40	SA3055101	N -48	28		J2 -13	20			
SA2688001	G -1	12	SA3057001	B -35	4	SA4028001	H -3	14			
SA2689001	G -10	12	SA3058101	B -36	4	SA4029001	J1 -3	16			
SA2691101	Z1 -17	50	SA3059001	B -38	4		J2 -3	20			
SA2692101	Z1 -18	50	SA3060001	N -37	28	SA4033001	N -11	28			
SA2693001	Z1 -35	50	SA3061001	N -30	28	SA4038001	J1 -4	16			
SA2695001	Z1 -36	50	SA3062001	E -1	10		J2 -4	20			
SA2696001	S -12	38	SA3065001	B -37	4	SA4040001	T1 -11	40			
SA2707001	V -1	48	SA3067001	E -41	10	SA4043001	J1 -36	18			
SA2712001	T1 -17	40	SA3072001	F -1	12		J2 -45	22			
SA2717001	J2 -32	22	SA3147001	N -25	28	SA4045001	J1 -37	18			
SA2722001	J1 -43	18		N -29	28		J2 -46	22			
	J2 -53	22		N -38	28	SA4049001	Ga1-	56			
SA2723001	N -19	28	SA3175001	T1 -12	40	SA4050001	Ga2-	63			
SA2724001	H -35	14	SA3414001	P -2	32	SA4051001	Ga2-	63			
	N -20	28	SA3415001	P -2	32	SA4053001	Ga1-	56			
SA2727101	N -31	28	SA3416001	P -2	32	SA4089001	B -2	4			
SA2728001	R -7	36	SA3417001	P -1	32	SA4095001	C -29	6			
SA2732001	S -11	38	SA3710001	C -6	6	SA4112001	B -16	4			
SA2754001	H -37	14	SA3711001	C -9	6	SA4115001	B -21	4			
SA2755101	J1 -1	16	SA3712001	C -10	6	SA4117001	C -38	6			
SA2757100	J1 -33	16	SA3840001	H -10	14	SA4118001	C -40	6			
SA2759001	L -6	26	SA3848001	C -17	6	SA4124101	C -1	6			
SA2761001	A -27	2	SA3852001	C -19	6	SA4129001	B -22	4			
SA2768101	Z1 -37	50	SA3854001	C -2	6		D -35	8			
SA2769001	Z1 -38	50	SA3855001	H -1	14	SA4166001	B -21	4			
SA2770101	Z1 -39	50	SA3856001	J1 -8	16	SA4194001	T1 -44	40			
SA2814101	N -13	28		J2 -8	20	SA4205001	N -1	28			
SA2818001	P -1	32	SA3859001	J1 -9	16	SA4212001	P -3	32			

brother®

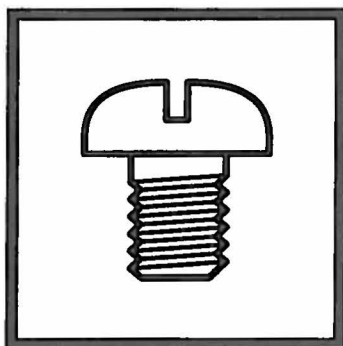

零件手册
PARTS BOOK

兄弟工业株式会社 <http://www.brother.com/>

日本国，名古屋市瑞穂区苗代町15番1号 邮编：467-8561 电话：81-52-824-2177

BROTHER INDUSTRIES, LTD. <http://www.brother.com/>

15-1, Naeshiro-cho, Mizuho-ku, Nagoya 467-8561, Japan. Phone : 81-52-824-2177

T-8421A,T-8422A
SA4168-001
2004.05.ZB (1)

